

SEEDS TOOLKIT

Module 2: Seed processing: principles, equipment and practice

Published by:
The Food and Agriculture Organization
of the United Nations
and AfricaSeeds
Rome, 2018

The designations employed and the presentation of material in this information product do not imply the expression of any opinion whatsoever on the part of the Food and Agriculture Organization of the United Nations (FAO), or of AfricaSeeds concerning the legal or development status of any country, territory, city or area or of its authorities, or concerning the delimitation of its frontiers or boundaries. The mention of specific companies or products of manufacturers, whether or not these have been patented, does not imply that these have been endorsed or recommended by FAO, or AfricaSeeds in preference to others of a similar nature that are not mentioned. The views expressed in this information product are those of the author(s) and do not necessarily reflect the views or policies of FAO, or AfricaSeeds.

ISBN 978-92-5-130950-6 (FAO)

©FAO, 2018

FAO encourages the use, reproduction and dissemination of material in this information product. Except where otherwise indicated, material may be copied, downloaded and printed for private study, research and teaching purposes, or for use in non-commercial products or services, provided that appropriate acknowledgement of FAO as the source and copyright holder is given and that FAO's endorsement of users' views, products or services is not implied in any way.

All requests for translation and adaptation rights, and for resale and other commercial use rights should be made via www.fao.org/contact-us/licence-request or addressed to copyright@fao.org.

FAO information products are available on the FAO website (www.fao.org/publications) and can be purchased through publications-sales@fao.org

This presents the underlying principles of seed processing, the equipment used and the overall best practices from reception through conditioning to final delivery to customers. This module focuses on the use of affordable small-scale equipment for seed processing and sowing that may also be fabricated locally.

Contents

FOREWORD	V
ACKNOWLEDGEMENTS	VII
INTRODUCTION	1
1 WHAT IS SEED PROCESSING?	3
Principles of seed processing	5
Properties of good seed	5
Benefits of seed processing	6
Steps involved in seed processing	6
Reception	6
Drying	7
Cleaning	12
Treatment	14
Weighing, packaging and storage	15
Types of machines used in seed processing	17
2 THRESHING AND PRE-CLEANING	19
Threshing	21
Manual threshing	21
Animal-powered threshing	21
Mechanical threshing	22
Pre-cleaning	24
Winnowing	24
Scalping	25
De-bearding	26
3 BASIC CLEANING	27
Manual basic cleaning	29
Air-screen cleaner	30
Types of air-screen cleaners	31
Adjustment and maintenance of air-screen cleaners	35
Other basic seed equipment in the processing plant	35
Feed or intake hoppers	35
Bucket elevator	36
Holding bins	38
Ducting	38

4	FINE CLEANING AND GRADING	41
	Indented cylinder	43
	Adjustment and maintenance of indented cylinder	44
	Gravity separator	44
	Adjustment and maintenance of gravity separator	45
	Other types of equipment	46
	Spiral separator	46
	Velvet roller	47
	Disc separator	48
	Electromagnetic separator	48
	Colour sorting machine	49
5	SEED TREATMENT, PACKAGING AND LABELLING	51
	Benefits of seed treatment	53
	Precautions in seed treatment	53
	Method of chemical application	53
	Seed treatment equipment	54
	Adjustment and maintenance of seed treater	55
	Labelling	55
	Packaging	56
	Weighing scale	56
	Bag stitching machine	57
	Stacking processed seed	57
6	PROCESSING-PLANT MANAGEMENT AND GENERAL MAINTENANCE	59
	Benefits of good operation and maintenance	61
	Types of processing-plant management and maintenance	61
	Maintenance of control panels and electric installation	63
	Maintenance of generator sets	64
	Summary	65
7	HEALTH AND SAFETY IN THE PROCESSING PLANT	67
	Housekeeping	69
	Dust collection and control	70
	Adjustment and maintenance of dust collection system	70
	Seed treatment	70
	General safety	71
8	SELECTING, OWNING AND MANAGING SEED-PROCESSING MACHINERY	73
	Benefits of owning seed machinery	75
	Selecting and owning the right seed-processing machinery	75
	Ordering and buying seed-processing machinery	76
	Managing seed-processing machinery	76
	Operator training	77
	Manuals	77
	Tools	78
	Records	78
	Housekeeping	79

Foreword

The global community, through the Sustainable Development Goals, has committed to achieving a world free of hunger by 2030. This will require the sustained production of about 60 percent more food than at present, food that is both nutritious and safe, and produced in ways that do not damage the environment. Under most scenarios, there are no surplus land or water resources to deploy to increase agricultural production. In fact, the most sustainable path to this goal is through enhanced productivity in a sustainable way. That means producing more yield with fewer external inputs. To support this, farmers need to use well-adapted crop varieties.

FAO and partners work with countries to increase farmers' use of quality seed and planting material of well-adapted varieties, particularly for the rural dwelling resource poor small-scale and family farmers who produce most of the food consumed in vulnerable communities of developing countries.

A country's seed delivery system is best conceived as a value chain composed of interrelated components – from the development of well-adapted and nutritious crop varieties and their adoption by farmers, through the production and distribution, including sales, of quality seeds and planting materials, to on-farm utilization of these inputs by farmers. The effective functioning of the value chain, enabled by the applicable national seed laws, policies, strategies, action plans and regulations, depends largely on the extent to which the stakeholders are able to put into practical use the relevant knowledge and skills required for producing quality seeds and planting materials.

This Seeds Toolkit has been developed to support practitioners along the entire seed value chain to acquire the knowledge and skills they need in order to deliver quality seeds and planting materials of well-adapted crop varieties to farmers. The Toolkit is designed primarily for capacity building activities, especially for small-scale farmers and small and medium-scale entrepreneurs, and contains six interrelated modules. These modules address: the setting up of small-scale seed enterprises; the processing of seeds; quality control; and the storage and marketing of seeds. There is also a module on seed regulatory matters. These easy-to-read modules of the Toolkit should also be useful for policy-makers and other practitioners interested in better understanding the workings of effective seed delivery systems.

Hans Dreyer

Director Plant Protection and Production Division

Acknowledgements

This module was produced by the Seeds and Plant Genetic Resources Team of FAO's Plant Production and Protection Division under the direction of Chikelu Mba (Team Leader).

AUTHORS

Samuel Kugbei, (former FAO Senior Officer), Mushira Avungana (international consultant) and Wilson Hugo (FAO)

TECHNICAL REVIEWERS

The manuscript was peer reviewed by Michael Turner (international consultant) and Mohammed Tazi (international consultant). It has also benefitted from the inputs and feedback by experts from African countries who attended a workshop organized by AfricaSeeds in Abidjan, Côte d'Ivoire.

EDITORIAL SUPPORT

Hamza Bahri and Diana Gutiérrez Méndez (FAO) coordinated the language editing, illustrations and layout. Ruth Duffy edited the document, Shalis Stevens drew the illustrations and Davide Moretti (Art&Design) undertook the overall design and layout of the publication.

Introduction

Seeds coming from the field after harvest usually contain undesirable materials which must be removed during processing to obtain clean seed suitable for planting. Seed enterprises often acquire specialized equipment for processing their seed, and they need technical guidance on the effective use and maintenance of the various pieces of equipment in order to enhance performance, minimize breakdowns and ensure prolonged machine life. This module aims to fulfil this need. It is intended as a **training guide** and **reference material** to be used by machinery operators, enterprise managers and all those involved in maintenance of seed-processing equipment.

The module is fully illustrated to aid understanding. The technical messages and information are placed in a practical context to facilitate application. It comprises eight chapters, each supplemented with exercises to stimulate discussion and exchange of ideas on key concepts and relevant practical details.

Chapter 1 explains what seed processing actually means and outlines the basic principles involved, the properties of good seed, the main benefits seed enterprises can derive from cleaning and packaging their seed, the key steps in the seed cleaning process and the various types of machines and equipment normally used.

Chapter 2 presents the first stages of seed processing: the threshing and pre-cleaning normally done on the farm before the partially cleaned seed reaches the seed enterprise to undergo further cleaning.

Chapter 3 discusses the main operation in seed processing – basic cleaning – carried out when the seed reaches the processing facility of an enterprise. The various components of basic cleaning, the operating details and maintenance schedules are explained.

Chapter 4 explains fine cleaning and grading and illustrates the details of the various steps involved.

Chapter 5 outlines the steps involved in adding suitable crop protection treatment to the seed and packaging it for distribution to farmers for sowing.

Chapter 6 outlines the general programmes and maintenance schedules that must be adhered to.

Chapter 7 describes the health and safety concerns relevant to seed processing.

Chapter 8 examines the benefits of owning a processing facility and explains factors relevant to the management of such a facility.

Remember! Seed processing is a **technical operation** requiring skilled, knowledgeable and experienced workers, able to make effective use of manufacturers' instruction manuals. This training module aims to supplement - not replace - existing user manuals or similar documentation. In some countries, seed-cleaning technicians receive professional training and must have a licence to operate seed-processing plants.

The **objective** is to help seed enterprises improve their end product. An efficient seed-processing and packaging system means they can deliver **high-quality seed** to farmers.

①

What is seed processing?

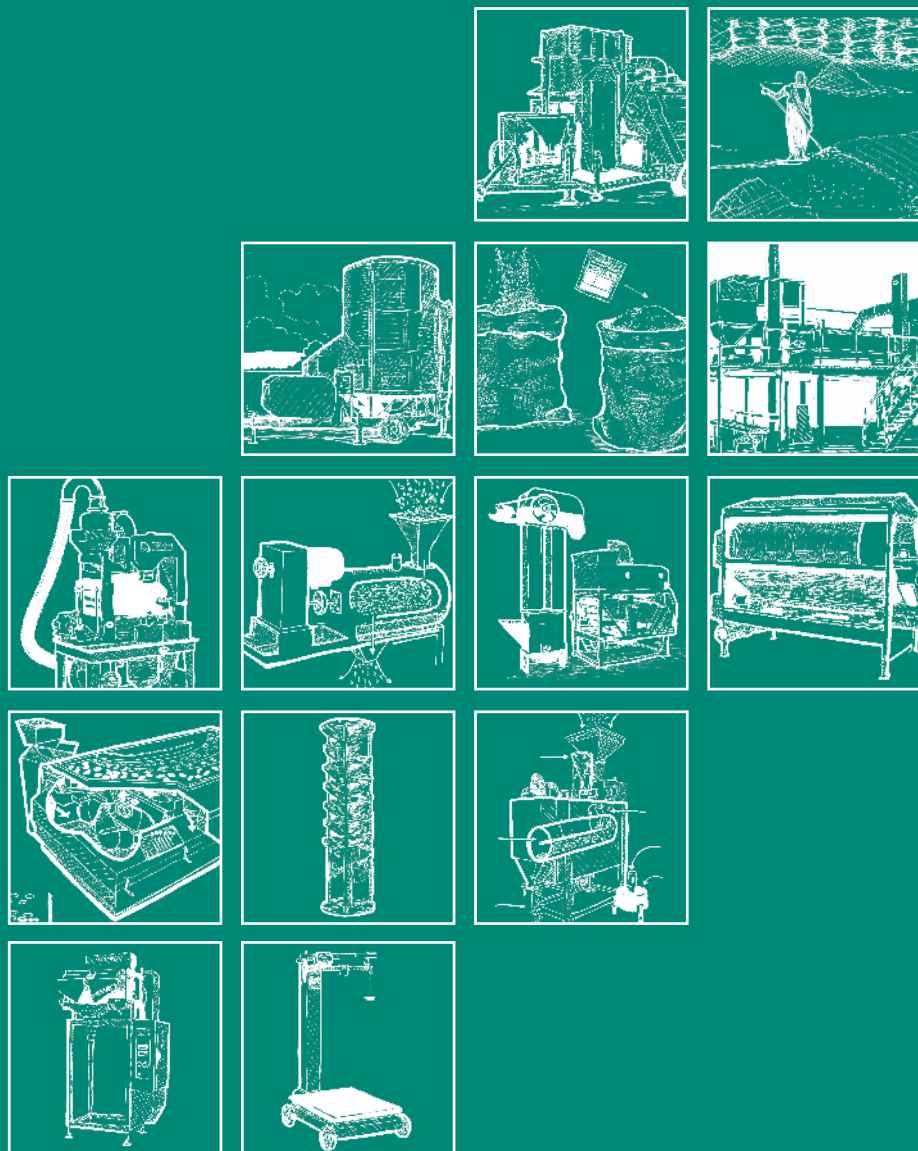

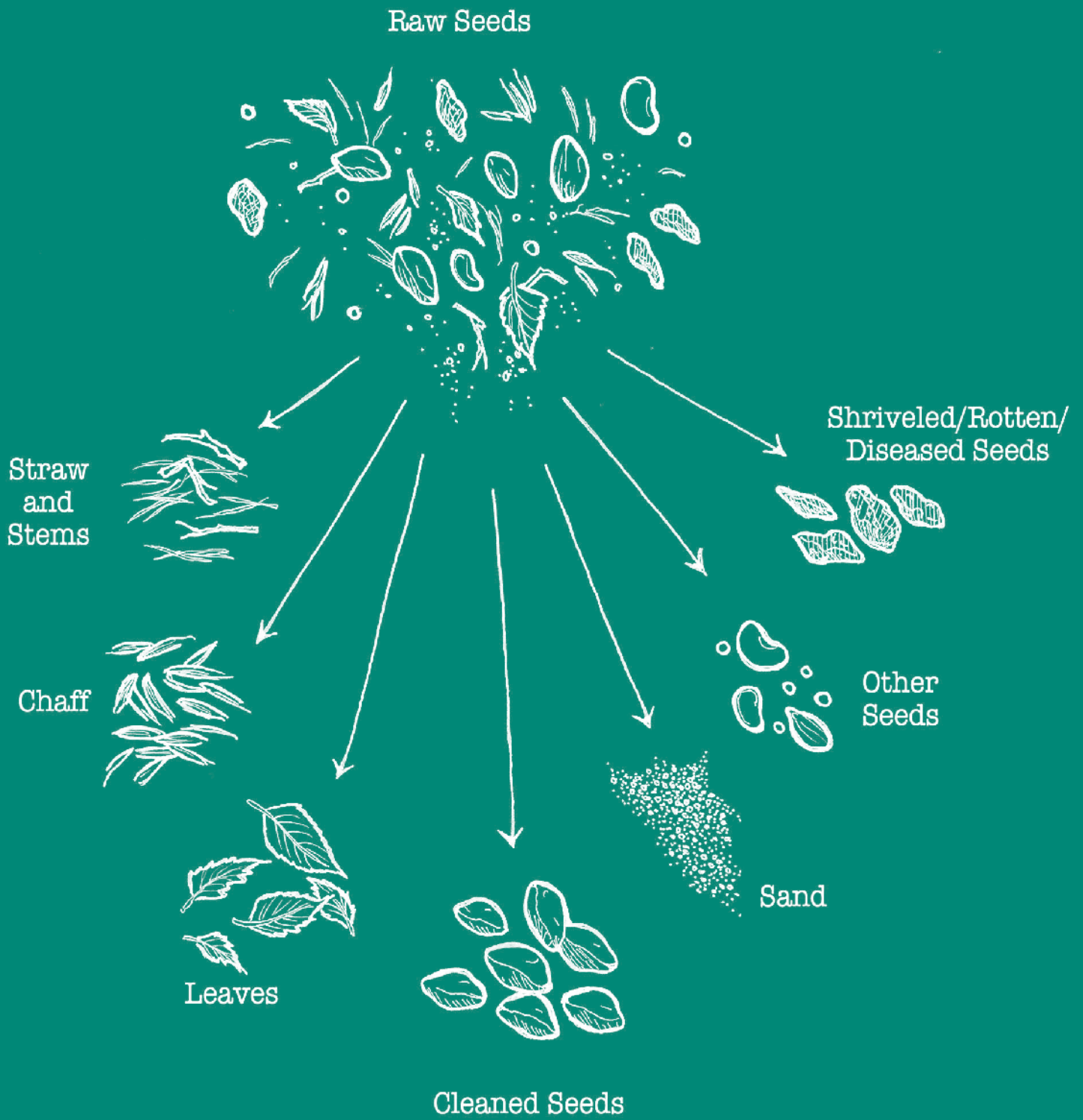

Raw seed and separation into its various components

What is seed processing?



After harvesting, seeds are threshed, dried, cleaned and tested before being stored and distributed to farmers for planting. Newly harvested and threshed seeds from the field often contain undesirable materials (e.g. stems, leaves and chaff; stones and soil particles; weed seeds and other unwanted seeds). It is essential to **remove impurities** to obtain good quality pure seed of the required crop and variety.

Seed processing or seed conditioning is the **preparation of harvested seed for marketing** to farmers. The processes involved include drying, threshing, pre-cleaning, cleaning, size grading, treating, quality testing, packaging and labelling.

PRINCIPLES OF SEED PROCESSING

Within the seed lot, both the pure seeds and any undesirable materials may present major **differences in physical properties**:

- size (length, width, thickness)
- shape
- weight/density
- texture (rough, smooth, pointed)
- colour

The seed-cleaning operation exploits these differences to separate the desired seed from the contaminants. However, the seeds of the required end product may not be uniform, including big and small, long and short seeds. Moreover, seeds and contaminants (e.g. weeds) without sufficiently different physical characteristics are not easily separated.

No single machine is capable of separating seeds on the basis of all the physical properties listed above. A **variety of cleaning machines** and equipment exist to separate seed according to specific physical characteristics.

PROPERTIES OF GOOD SEED

Quality seed must meet certain **quality standards** in the laboratory:

- Moisture content (max. %)
- Physical purity (min. %)
- Germination capacity (min. %)
- Seed health (maximum incidence of diseases or insects)
- Genetic or varietal purity (min. %)

notes

Undesirable materials in raw seed

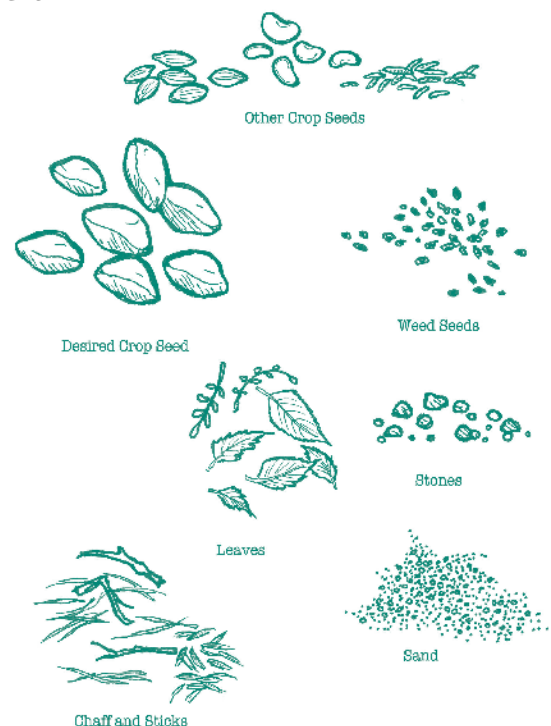

notes

Note that visual examination cannot ascertain varietal purity, since seeds of different varieties of the same crop tend to share the same physical characteristics. Varietal purity is therefore normally determined by examining the growth stages of the crop during field inspections prior to harvest.

Quality standards differ depending on the seed class¹. Standards for early generation seed classes (pre-basic/breeder and basic/foundation) are higher than those for later generation classes (registered and certified).

BENEFITS OF SEED PROCESSING

In addition to enhanced purity, health and germination, well-cleaned and good quality seeds have other benefits, all of which increase their **market value**: improved visual appearance, reduced seed rate, uniform emergence and crop stand, high yield and long shelf-life.

STEPS INVOLVED IN SEED PROCESSING

The **principal operations** in a seed-processing plant are reception; drying; cleaning and grading; treatment; and weighing, packaging and storage.

Reception

Seed processing begins with reception of the raw seed at the processing plant. It can arrive bagged or in bulk, dried or not, and with varying levels of impurities. Weigh and properly identify the seed lot and assign a seed lot number for future traceability. Mark the seed lot clearly with its seed lot number and take a sample. Dry the seed to the correct moisture content and test with a hand-held electronic moisture meter.

Bagged seed is easier to identify than seed in bulk. Send sealed and labelled bags directly for cleaning or keep in interim storage on wooden pallets for processing at a later stage. Check seeds received in bulk to ensure that no admixture with seed from other seed lots occurred between harvesting and arrival at the processing plant.

Testing seed using an electronic moisture meter



¹ There are two main international schemes for the certification of seed:

- Organisation for Economic Co-operation and Development (OECD) Seed Schemes, with voluntary membership open to all members of the OECD, UN member countries and UN specialized agencies. OECD recognizes three classes of seed: pre-basic, basic and certified.
- Association of Official Seed Certifying Agencies (AOSCA), an association of certifying agencies in the United States/North America and other global members. AOSCA recognizes four classes of seed: breeder, foundation, registered and certified.

Once several seed lots are in store, decide the processing order of the different varieties and lots. Consider the total number of lots and the time required between harvesting and the next planting season. Minimize changes between varieties to reduce the risk of contamination.

Consider who actually owns the seed lot. Possible **owners**:

- **Seed-processing enterprise and producer** of the raw seed. The enterprise may make decisions regarding the seed without consulting any other party.
- **Contract grower** of the seed-processing enterprise. The contract grower sells the seed and receives payment from the enterprise once the seed is clean, meeting the minimum quality standards.
- **Paying customer** (farmer or another enterprise) requesting seed-cleaning services of the processing plant. Any problems arising during storage/processing (e.g. damage due to pests, mice or moisture) are the full responsibility of the seed-processing enterprise.
- **Seed-processing enterprise and buyer** of the raw seed from a non-contract grower. The enterprise takes full responsibility if the seed does not meet the minimum quality requirements.

Drying

Drying reduces the moisture content of the seed to the recommended levels for seed processing and storage. Drying seeds not only increases longevity in storage, but also prevents attack by pests and pathogens. Seed moisture content is key to the longevity of seed in storage. **High moisture content:**

notes

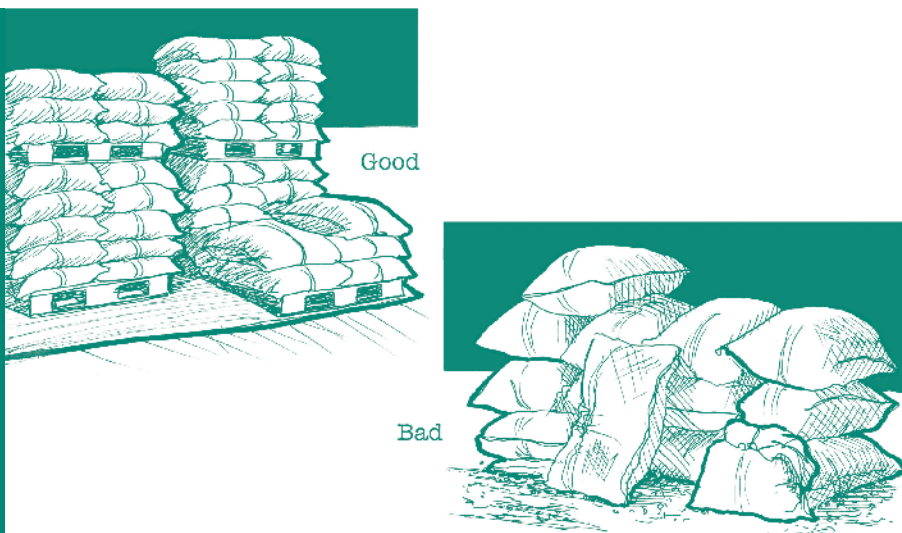

Good and bad ways of storing seed

notes

- increases the respiration rate of seeds, raising the temperature within the seed lot to potentially fatal levels;
- causes growth of mould detrimental to the health of the seeds; and
- decrease of percentage of germination.

After harvesting and threshing, dry seeds promptly to prevent deterioration. Choose a drying method based on the prevailing conditions and the quantity of seed to be dried. Low-cost drying options include sun drying and other mechanical methods appropriate for small-scale seed enterprises. The techniques adopted must not be detrimental to seed viability and vigour.

In many situations, it may be sufficient to **air dry** the seed. Leave the seed in an environment with low relative humidity and at a relatively low temperature until the seed moisture content reaches an equilibrium. Air-dried seed can remain viable until the next planting season. However, in tropical climates with high relative humidity, it is more difficult to maintain drying conditions at low relative humidity.

Sun drying

If dried in the sun, the temperature should not exceed 35°C. If the temperature goes above that limit, it is necessary to take action to protect the seed, covering it or moving it to an area with a lower temperature. As the seed moisture content decreases, it reaches a point of equilibrium with the relative humidity. The rate at which this equilibrium is reached depends on the species, size and condition of the seed. The drying process is fast initially, and then gradually slows down. Once the seed is sufficiently dry, take samples to determine the moisture content using a hand-held moisture meter.

Sun drying and swirling of seed



1

Mechanical seed drying

In tropical countries, seed drying is a major problem for farmers and enterprises, especially when the harvest coincides with wet weather. Simple mechanical dryers offer an effective solution. Unlike traditional sun drying, heated air drying permits the creation of **uniform air conditions**. Mechanical drying produces better quality seed than traditional sun drying and is, therefore, usually recommended for the production of premium quality seed.

Heated-air mechanical dryers normally dry seed in batches. A certain amount of seed is dried at a time, depending on the volume or holding capacity of the dryer. In **batch drying**, take into account the loading and unloading time for each batch of seed to be dried.

Batch drying bins may be stationary or portable. There are two main types:

- static; and
- recirculating (and continuous-flow).

Static grain dryers

The most common static or fixed-bed dryers are **flat-bed** dryers. Simple machines, they are designed for use at farm or village level. With a daily capacity of 1–3 tonnes, small-scale flat-bed dryers are easy to construct (using locally available and cheap materials) and straightforward to operate. The walls of the drying bin are constructed using wood, brick or metal. The floor of the drying chamber is made from fine wire mesh (suitably supported) or perforated metal. They come in different shapes and typologies: thin layer bed, thick layer bed, thin layer vertical column and circular structure.

Lay the seed on a perforated screen, and force air up from below. The air fan is usually a simple axial flow fan powered by a diesel engine or electric motor. It may also be powered by kerosene burner, biomass stove or solar power. The air temperature is set according to the desired safe storage moisture content of the seed.

notes

Diagram of Static dryer

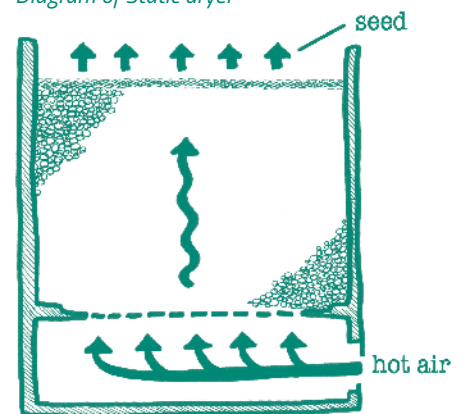

Operation of flat-bed seed dryer

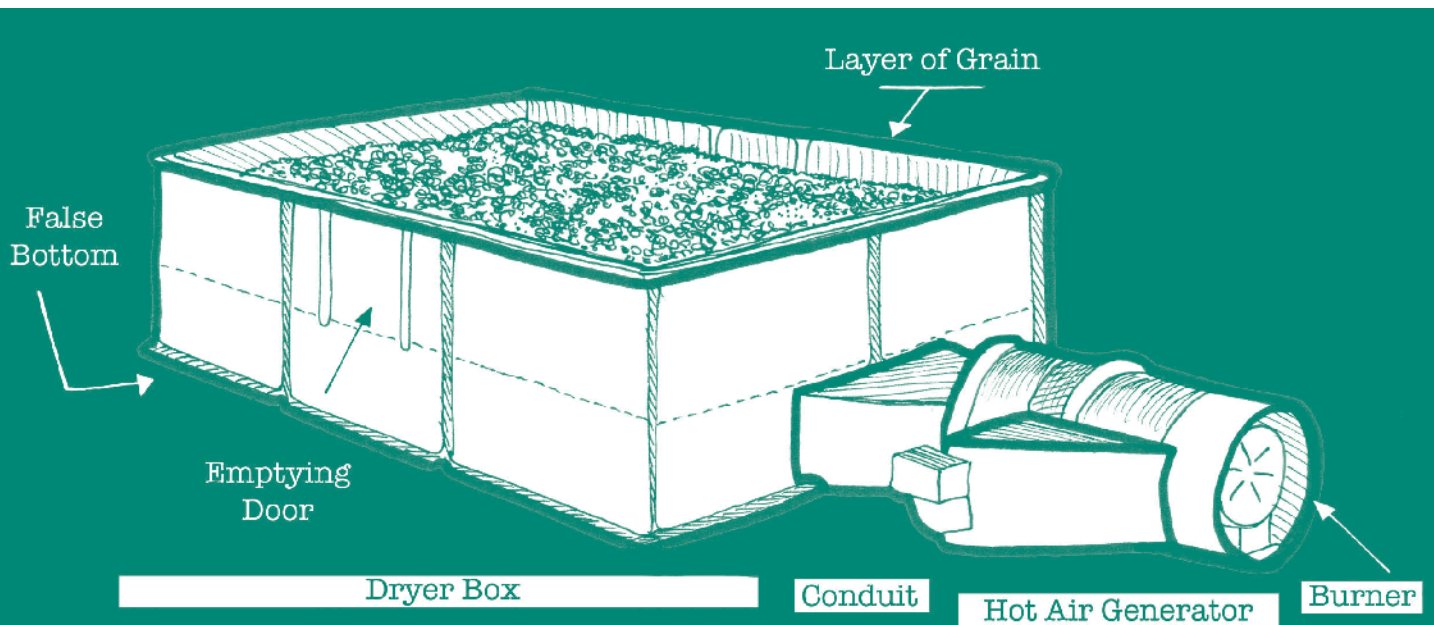

notes

A **disadvantage** of the static grain dryer is that **moisture gradients** form through the bed. The grain nearest to the wall of the incoming hot air becomes over-dried as it is the first to lose moisture to the hot air. The air absorbs the moisture given off from the grain, resulting in a reduction in air temperature. The capacity of the hot air, therefore, decreases as it moves through the grain bed. The difference in moisture content between the layer of grain nearest to the hot air and the outer layer varies according to grain thickness, hot air temperature and airflow rate.

In order to avoid excessive moisture gradients in the bed, keep the depth of seed in the bin relatively shallow.

Some manufacturers have introduced devices for reversing the airflow in fixed-bed dryer models. This reduces the moisture gradient, eliminates the need for mixing and improves the quality of the dried seed, although it entails additional costs. The most basic model requires a relatively **low initial investment**.

Recirculating grain dryers

Recirculating batch dryers can handle large amounts of seed in the peak season and produce high-quality grain. Mixing the seed during drying avoids the problem of moisture gradients experienced with flat-bed bin dryers.

The most common version of a recirculating batch dryer is a self-contained unit comprising a tall vertical drying column around a central plenum chamber (for mixing); a fan and heater; and a central auger (for transporting the grain from the bottom to the top). Most dryers of this type are portable, easily transported from farm to farm.

Design of the mixed grain batch dryer

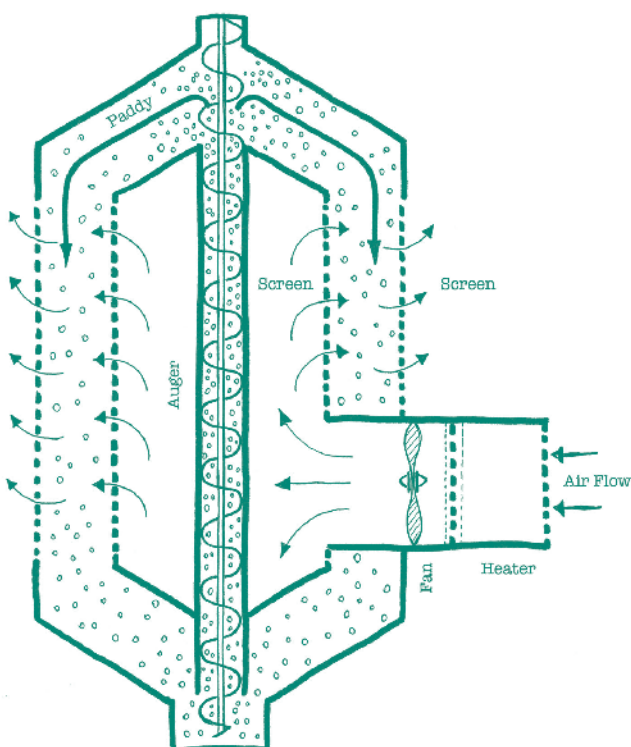

1

The discharged grain is recycled back through the dryer 3–4 times until its moisture content reaches the desired level. Once dried, the grain is discharged from the top. The recirculating dryer results in uniform grain moisture content.

A **disadvantage** is that the loading, unloading and circulation of grain can create **dust**, which must then be removed and collected. It is recommended to pre-clean the seed prior to loading and drying.

In each cycle, the grain is exposed to the flow of hot air for relatively short periods and does not dry too rapidly. Furthermore, the moisture distribution within the individual grains is rebalanced whenever the grain is in the non-drying sections at the top and bottom of the dryer. To control the drying rate, adjust the auger speed regulating the flow of grain.

The **capital investment is considerably higher** than for flat-bed bin dryers. They are complex machines and include handling and conveying devices. On the other hand, **throughput is greater** due to the shorter drying times and the quality of the dried grain is likely to be higher. Recirculating batch dryers require specialist skills for construction and trained workers for successful operation; they are, therefore, not generally suitable for operation by small-scale farmers or enterprises.

Continuous-flow dryers

Continuous drying means that the grain flows continuously through the dryer without stopping. Continuous-flow dryers are an extension of recirculating batch dryers. Indeed, the dryer has the same features as a mixed or recirculating dryer. However, it requires several buffer bins to hold the discharged seed.

Continuous-flow drying is more common in large grain complexes. The system can handle a large quantity of grain and it offers greater flexibility. The continuous drying system has lower operating costs than batch drying. Furthermore, it produces a uniform grain moisture content and its drying capacity is higher than that of the mixing grain batch dryer.

Continuous-flow dryers move seed through the heating and cooling sections of the column without interruption. However, rather than the grain recirculating from bottom to top, as in the recirculating dryer, the grain is removed from the bottom and conveyed to tempering or storage bins. In the simplest dryers, there is a garner (or holding) bin on top of a tall drying compartment. In other more complex dryers, there is also a cooling section below the drying compartment and ambient air is blown through the grain as it is removed. At the bottom of the dryer, the flow control section regulates the circulation of grain through the dryer and its discharge.

Compared with static dryers and recirculating batch dryers, continuous-flow dryers have the greatest drying capacity. The equipment is expensive and **initial costs are high, but the operating costs per tonne can be relatively low,**

notes

Diagram of operation pattern of the continuous drying system

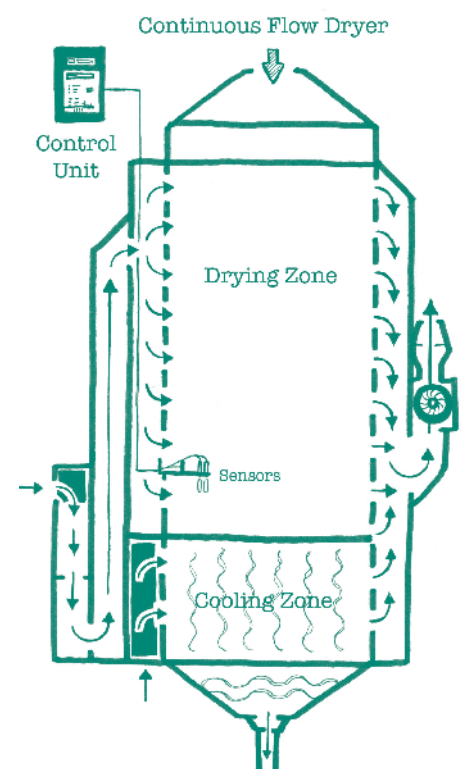

notes

given the potential for handling large quantities. Continuous-flow dryer operation requires carefully planning and good management to optimize the investment. The operator must have a good knowledge of grain drying management to be able to programme the dryer to operate at maximum efficiency.

Guidelines for using mechanical grain dryers

Installation:

- Choose with care - select a model based on technical requirements, economic feasibility and volumes of paddy to be dried.
- Know your dryer - understand the drying process, learn how to operate your dryer and request proper training from the manufacturer.

Before loading:

- Clean the grain - remove fines (they reduce the airflow, causing wet spots and increasing the drying time) and remove green, immature grains, straw and other materials (they extend the drying time, resulting in increased energy consumption).

Drying:

- Do not mix dry with wet paddy - air gains moisture as it passes through the dryer and may cause the dry grains to fissure.
- Monitor the drying air temperature – avoid heat stress (it can cause cracking) and ensure the viability of the seeds.
- Monitor the moisture content – stop the drying process at the desired level (too high = reduced quality and lower returns, too low = weight loss and reduced profits).

Cleaning

Pre-cleaning

Pre-cleaning involves the rapid removal of materials that are either substantially larger or very light and much smaller than the crop seed. It may also include the removal of awns or beards – stiff bristles growing from the ear of cereal grains (e.g. wheat, barley, rye and many grasses).

Pre-cleaning is not always necessary, for example, with certain hand-harvested and winnowed seeds. The objective is not to obtain quality seed, rather to **facilitate subsequent operations**. Pre-cleaning:

- reduces the size of seed lots;
- simplifies the cleaning process;
- decreases seed loss during cleaning; and
- removes particles that may be problematic during interim storage (e.g. mould-inducing green material and live insects from the field).

1

Basic cleaning

Basic cleaning follows pre-cleaning and is the most important step in the seed-cleaning process. It removes all the undesirable materials from the seed and improves the physical purity of the seed lot. For many seed lots, basic cleaning is the fundamental step towards achieving the finished product.

notes

Raw seed and pre-cleaned seed

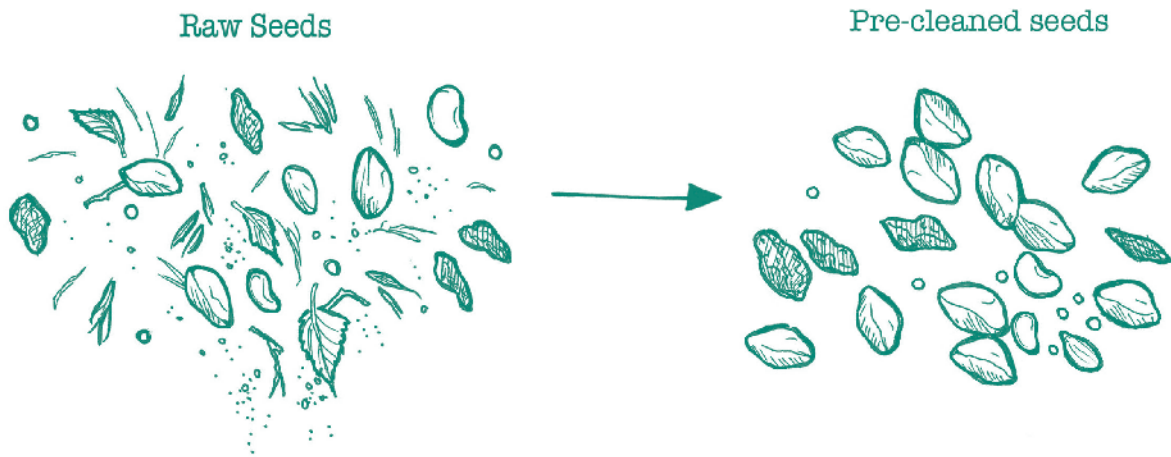

Pre-cleaned seed and cleaned seed

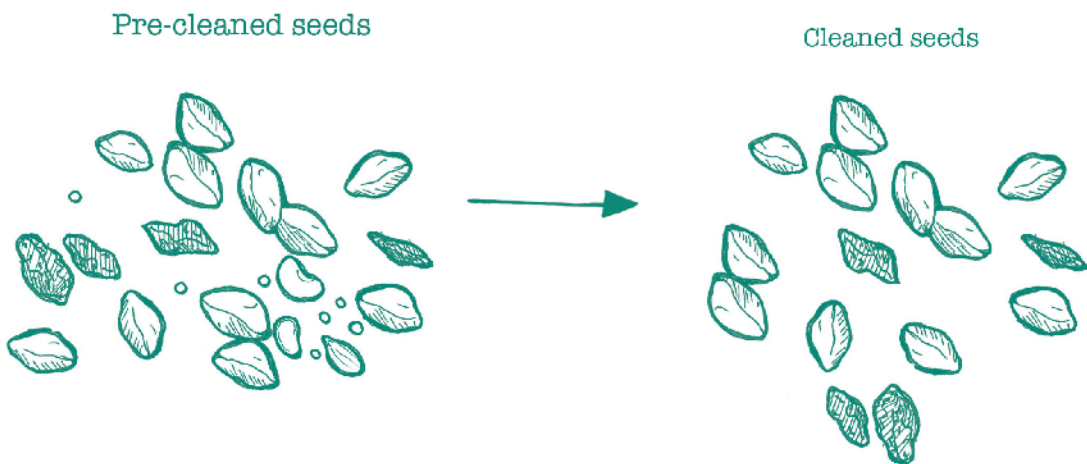

notes

Fine cleaning (grading)

Fine cleaning – or grading – improves the quality of the cleaned seed. Grading aims to achieve the highest possible level of purity and normally targets specific contaminants. The cleaned seed may also be separated by quality (e.g. size, shape, weight/density and colour).

During pre-cleaning, basic cleaning and fine cleaning, take samples for a rapid purity check and adjust the machines as necessary.

Treatment

All possible contaminants have been removed and the seed has been graded; it is now ready for bagging. First, however, consider whether chemical treatment (fungicide or insecticide) is required. Only treat seed if absolutely necessary. Use only properly labelled chemicals, specifically registered for seed treatment. Do not use chemical products not designed for seed treatment. Appropriate treatments stick properly to the seed and have a distinct colour to indicate that the seed has been chemically treated.

Crop protection products come in the form of:

- powders - applied directly to seed (rarely used due to the risk of the operator inhaling the powder); and
- wettable powder/grains or dilutable liquids – mixed with water and applied to seed with specially designed treating machines.

Cleaned seed and graded final seed

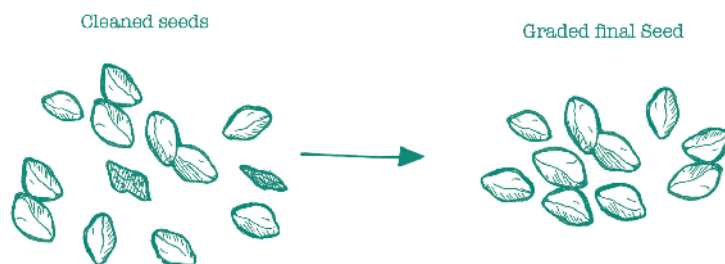

notes

Labelling

Once packaged, the bags are labelled to indicate that the seed has passed the quality control tests. For certified seed lots, the certification agency normally provides official labels. Alternatively, for non-certified seed or when the seed company is accredited for certification, it produces its own labels. Each country has its own legal requirements regarding labelling; these must be met. Once packaged and labelled at the processing plant, the seed is transported directly for sale or held in storage until needed.



Different kinds of seed storage materials



Weighing and sewing bags of quality seed

TYPES OF MACHINES USED IN SEED PROCESSING

Some seed-processing operations may be done manually. Nevertheless, it is generally preferable to use specialized machines; they are consistent, efficient, quick and capable of handling large quantities.

Various machines are set up and interconnected in the seed-cleaning plant to receive and handle the seed; clean, grade and treat the seed; and package and label the final product. Each machine performs a **specific task**, for example:

- Scalper and de-bearder - pre-cleaning
- Air-screen cleaner - basic cleaning
- Indented cylinder and gravity separator - fine cleaning

Seed-processing plants are classified according to mobility and layout:

- **Fixed (stationary)** - installed in single or multistorey buildings; large capacity (≥ 1 tonne/hour) for cereal crops.
- **Mobile** - installed on platform trailers that can be easily moved from one location to the other; smaller capacity.
- **Portable** - placed or mounted on desk tops, laboratory benches or floors (useful for training purposes); small capacity.

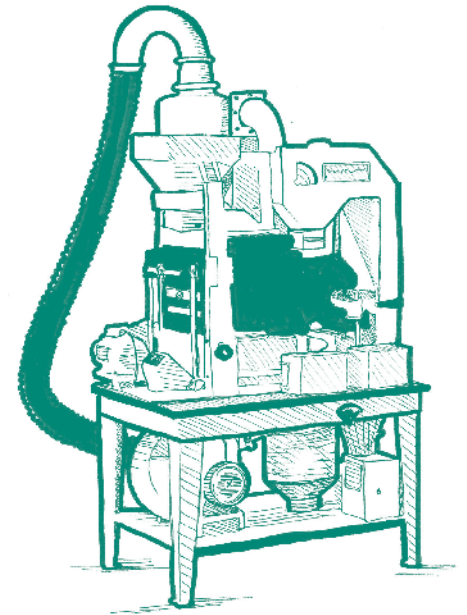

Small-scale laboratory seed cleaner

Layout of fixed seed-processing plant

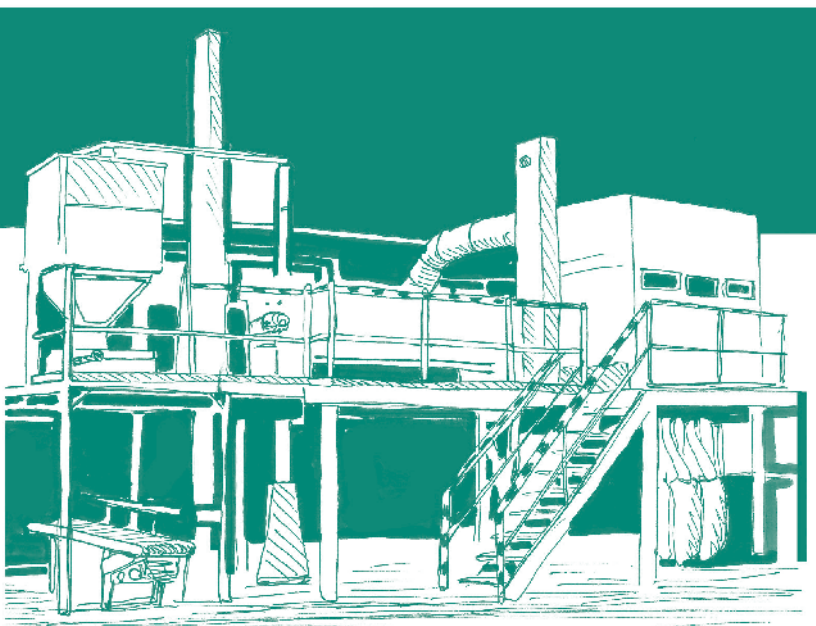

Complete mobile seed-cleaning machine

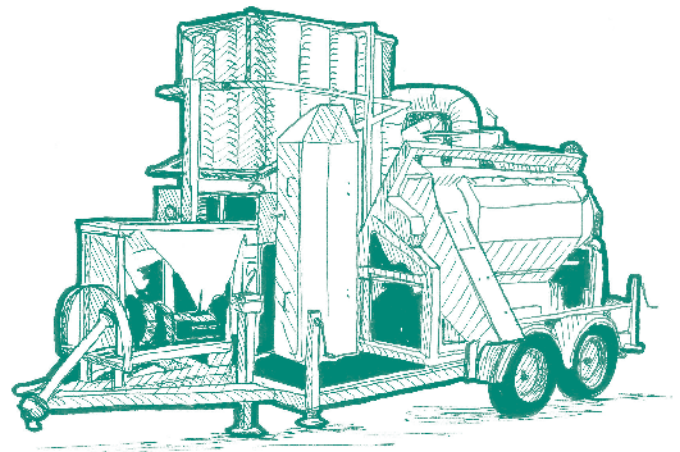

notes

EXERCISES AND DISCUSSION POINTS

1. As an owner of a seed-processing plant, what advice would you give to farmers in your community who buy grain from traders in the local market to plant as seed, rather than using processed, well-cleaned seed?
2. Why is it difficult to separate certain unwanted contaminants from the desired pure seed during processing? As an operator in a seed-processing facility, what would you do to improve this process?
3. Briefly describe a seed-processing plant you own or are thinking of buying. Explain the roles of the various key components.

② Threshing and pre-cleaning

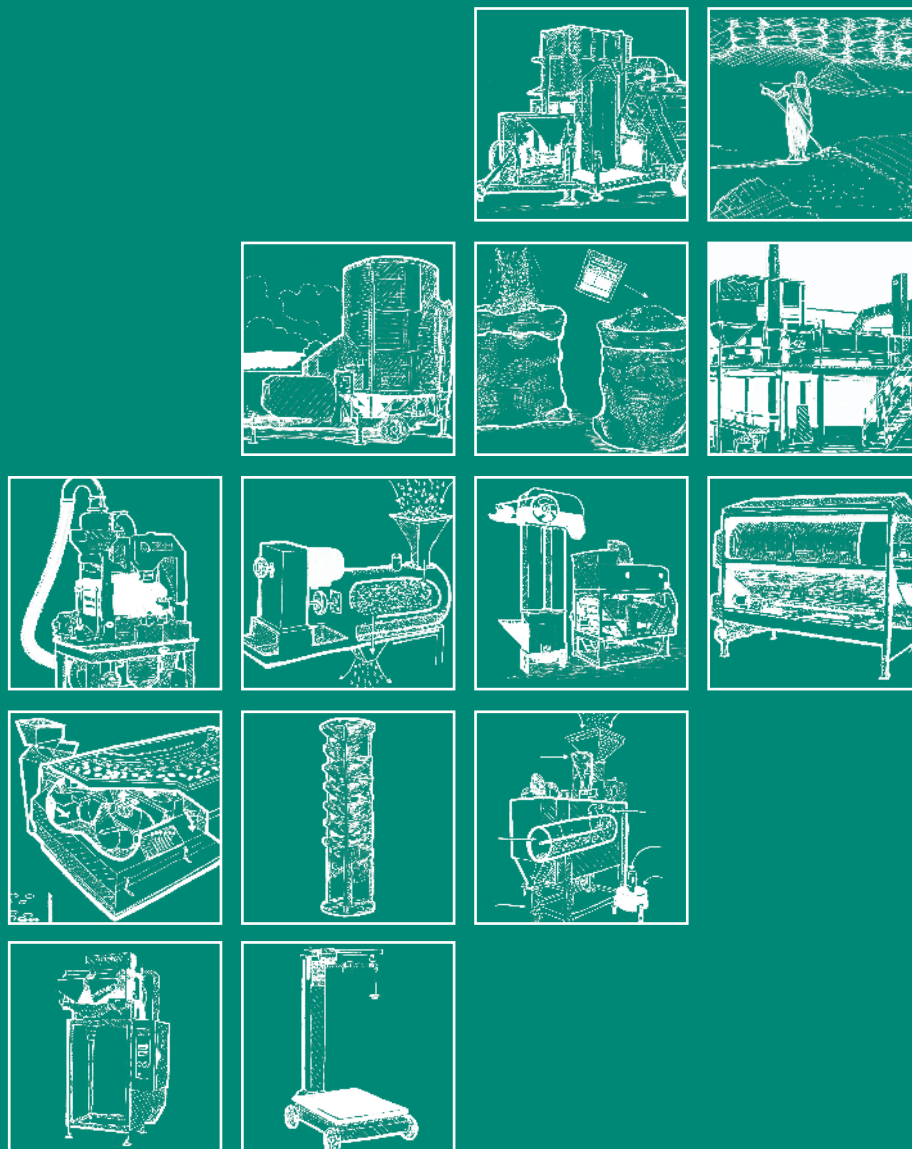



Threshing and pre-cleaning

2

After the seed is harvested, it undergoes various procedures to convert it from raw seed to clean seed, which is then tested for quality attributes before being made available to farmers as quality seed. Seed processing begins **in the field** with threshing and pre-cleaning.

notes

THRESHING

Threshing is the separation of the seeds from spikes and straw. Traditionally, seeds are threshed manually or using animal power. Nowadays, mechanical threshers are also available.

Manual threshing

Farmers beat the crop repeatedly on the floor with flails or other wooden objects to separate the seeds from the spikes and straw. Manual threshing is labour-intensive and expensive for large quantities of seed; furthermore, it may cause physical damage. Simple threshing tools include maize shellers and pedal-powered threshers for cereals.

Animal-powered threshing

Animals (e.g. oxen or donkeys) trample on the harvested material to separate the seeds from other plant parts. Although slow, this method is gentle and results in a low level of mechanical damage to the seed.

Animal-powered threshing method

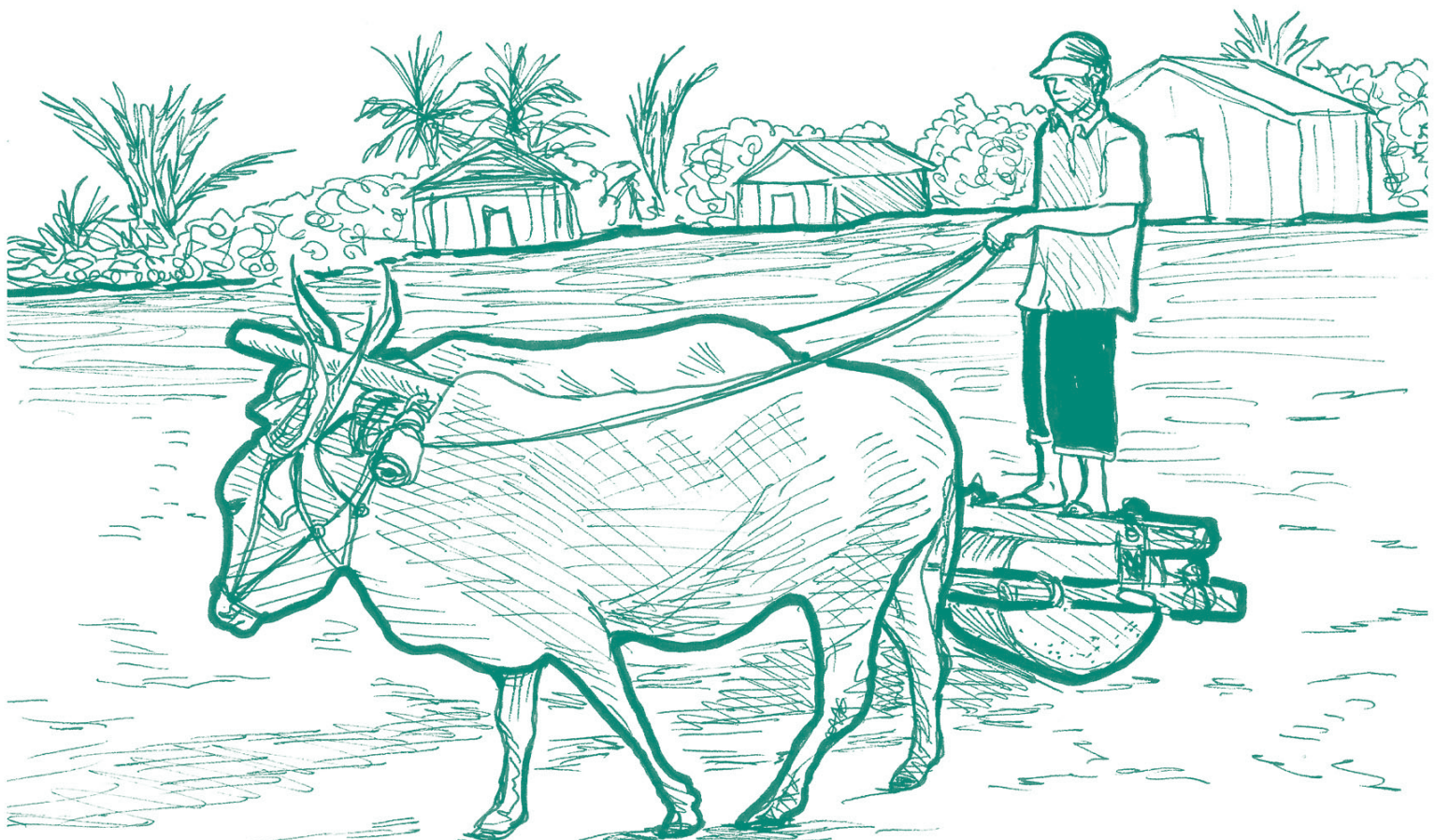

notes

Mechanical threshing

Mechanical threshers may be **stationary** and engine-powered or **mobile** and tractor-propelled. The main advantage of mechanical threshing is that farmers can carry out large-scale operations in a short time. The disadvantage is that the seed can get damaged; take care to regulate the machine properly to minimize physical damage to the seeds.

The threshing machine comprises two main components encased in steel plate: the **cylinder** (threshing drum) and the **concave**. The cylinder is made of serrated bars built around a strong shaft; it rotates around bearings mounted at each end. The concave is curved to match the cylinder. It has perforations and is stationary.

Other components are the inlet and the outlets for seed, straw and chaff. Some designs include a fan, screens and a conveyor system (e.g. screw conveyor or belt) for moving the stalks, seed and straw. The rotating cylinder, fan and conveyors all run on electricity.

Mechanical threshing method

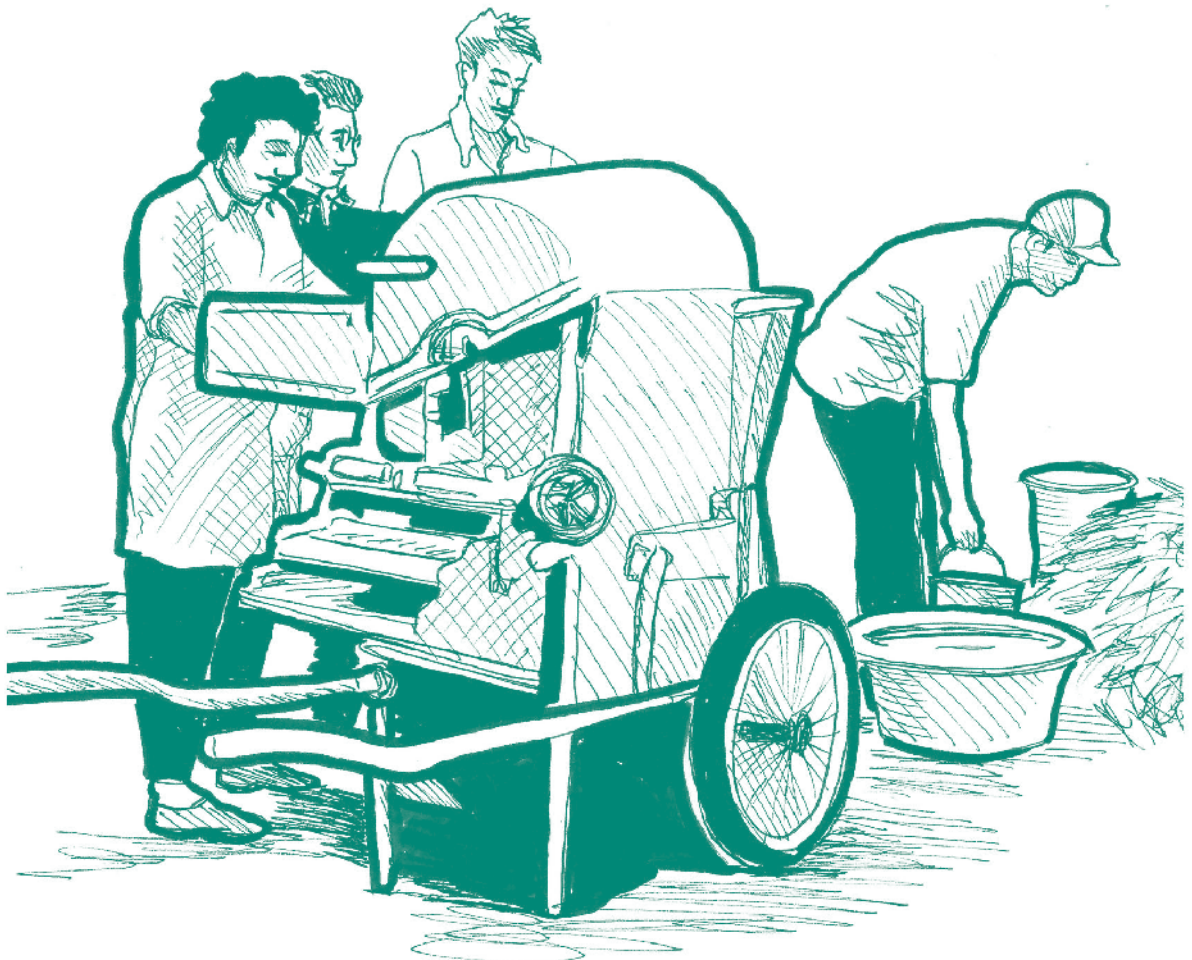

2

Operation steps:

- Stalks or bundles of crop are fed (usually by hand) into the threshing chamber via the inlet feed-hopper.
- Rotating cylinder draws stalks into the threshing chamber where they are beaten to remove seeds.
- Current of pressurized air separates lighter material (e.g. dry leaves, stems and dust).
- Concave retains material long enough to ensure that the stalks are sufficiently beaten and the seeds separated from the straw.
- Seeds and fine chaff fall through the concave and are winnowed by fanned air to remove the chaff.
- Seed is discharged onto a conveyor, bag or heap.
- Straw is discharged separately from the threshing chamber onto another conveyor, bag or heap.

For good thresher performance:

- Regulate the distance between the concave and cylinder – “concave clearance” - according to the crop type.
- Adjust the rotation speed of the cylinder according to the crop conditions.
- Control the crop feed rate into the threshing chamber.
- Adjust the power of the wind pressure to remove as much light material as possible without wasting seeds.
- Assess the moisture content of the grain, the stems and the ears/panicles before threshing.

notes

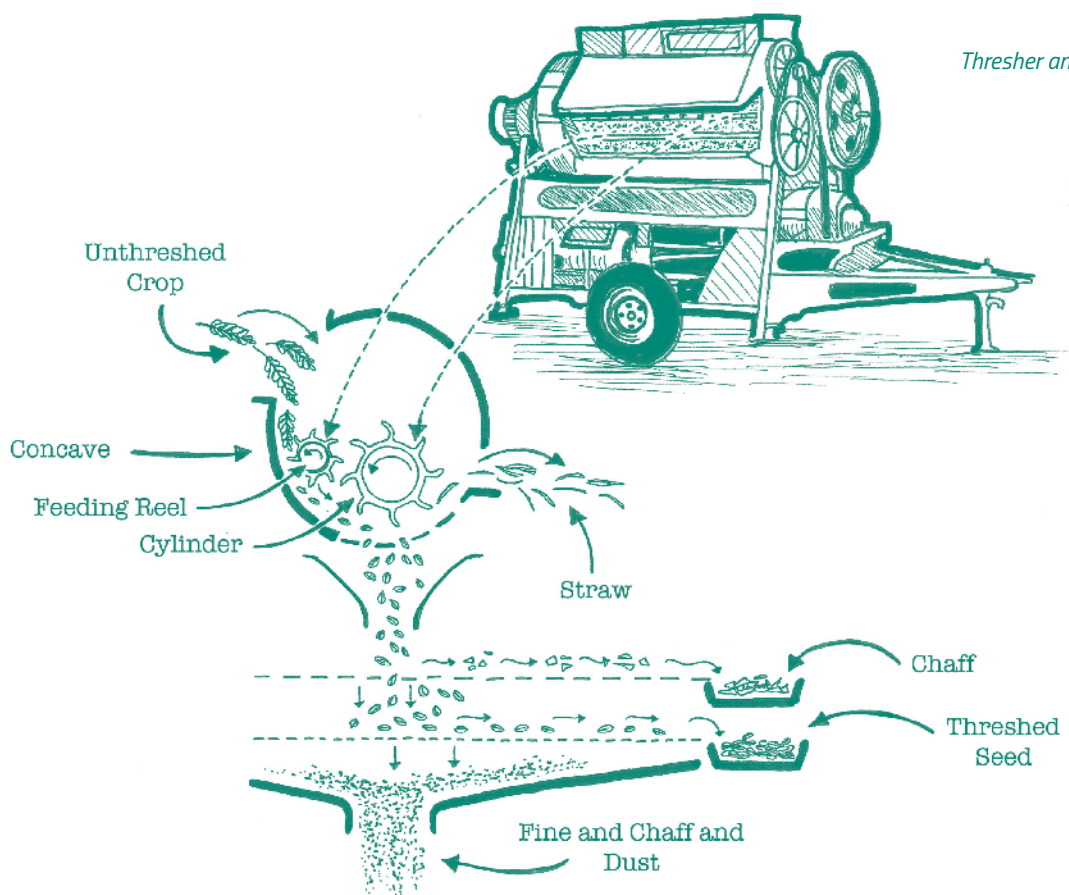
Thresher and working parts



Winnowing process using container and wind

Assessment of the **moisture content** is vital. The drier the plant material, the better it is for extracting seeds. On the other hand, overdried seeds are more prone to mechanical damage within the cylinder and concave. The moisture held by the plant material varies according to the time of day; use experience and physically examine the harvested material to choose the best time of day for threshing.

PRE-CLEANING

Pre-cleaning is the preparation of the threshed seed for subsequent processing operations (e.g. drying and basic cleaning). It involves the rapid removal of impurities that are either very fine or very large compared to the seed, and the breakage or dispersal of materials in clusters. Pre-cleaned seed flows better and improves the overall performance of the processing plant. It is important to dry and pre-clean seed as soon as it arrives at the processing plant. Pre-cleaning involves winnowing, scalping and de-bearding.

Winnowing

Winnowing separates **heavy** and **light** material. Simple winnowing trays are used; alternatively, the material is dropped through a stream of wind onto a clean area on the ground. Mechanical threshing sometimes incorporates the winnowing process.

Winnowing process using a spade and wind



Winnowing process using a fan



2

Scalping

Scalpers are available in various forms. One common type has two screens to separate the seed into three portions. The screens are fixed at a slight incline and then mechanically vibrated as the raw seed passes through. The raw seed is fed onto the top flat screen, which removes large debris, straw, leaves and other chaff. The seeds and other small particles fall through onto the screen below. The seed on the second screen is discharged into a hopper, while smaller impurities fall through the holes of the lower screen and are swept away by a draft of air.

Another type of scalper is a round drum made from perforated metal and set at a slight incline. The drum rotates and the seeds fall through the perforations; the debris remaining in the drum is removed.

notes

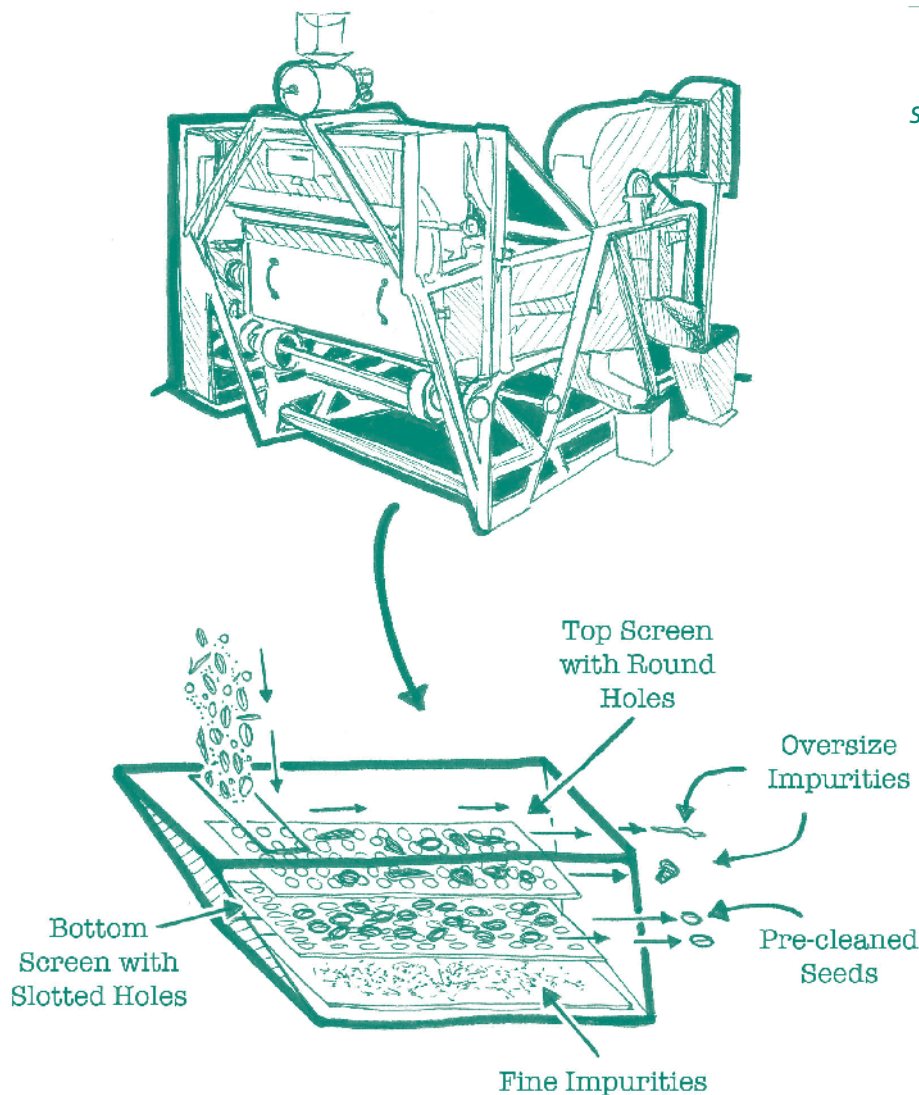

Scalping process

notes

De-bearding

The de-bearder – or de-awner – breaks down clusters of material. It removes awns, beards, tips or glumes on certain seeds (e.g. oats and barley) to improve the flow of seed through the cleaning machines. It is installed in front of air-screen cleaners; there is a bypass mechanism for seeds that do not require de-awning. The de-awner is enclosed in a steel case and equipped with a shaft fitted with staggered steel beaters; the shaft rotates and the beaters break up the material as it passes through the machine. Regulate the rotation speed of the shaft, and adjust the distance between the beaters and the discharge shutter to limit damage to the seed.

De-bearding process

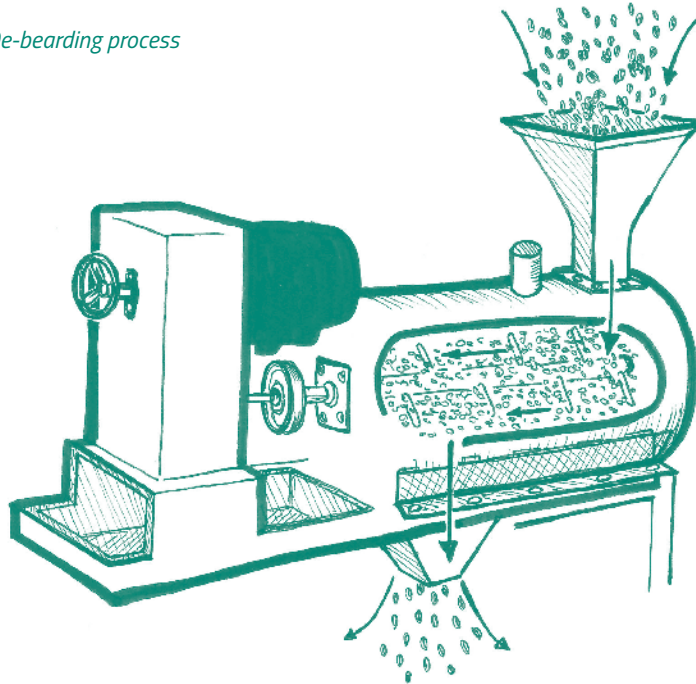

EXERCISES AND DISCUSSION POINTS

1. After harvesting, how do you know that the harvested material is ready for threshing? What methods can you use to thresh cereal seed to ensure good quality seeds?
2. How can you reduce mechanical damage to seed during threshing?
3. Explain why cereal seed threshed by mechanical threshers may not require pre-cleaning.
4. How can the presence or absence of scalpers or de-bearders affect the seed-cleaning process?



Basic cleaning

3

Basic cleaning is the **main operation** in seed processing and involves the removal of all materials other than the required seed. Manual basic cleaning is only possible for very small quantities. For larger quantities, mechanical basic cleaning is necessary. The machine normally used for basic cleaning is the air-screen cleaner – the vital component in every seed-processing plant.

MANUAL BASIC CLEANING

Manual methods include:

- hand-picking to eliminate impurities (e.g. off-coloured beans) on some kind of "sorting table"; and
- sieving to remove damaged grains or other unwanted particles.

notes



Picking seeds by hand



Sieving seeds by hand

notes

AIR-SCREEN CLEANER

Principles of air-screen cleaner operation

The air-screen cleaner is widely used and achieves a high level of physical purity. It is based on screens and a stream of air, and separates the seed lot into various quality fractions based on size (length, width and thickness), weight and density. The process entails three main steps:

- **Aspiration by suction air** - removal of light particles from the mass of seed. Aspiration can be before or after screening - or both before and after.
- **Scalping** - removal of coarse impurities. They are channelled to an outlet spout, while the remaining seed moves onto grading screens.
- **Fine cleaning** - removal of oversized and undersized seeds and other particles (e.g. stones and sand). The cleaned seed goes into the outlet for bagging or further processing.

The screens are made from steel plates and are available with different sized perforations, including round and oblong (slotted), triangular, and wire mesh. The choice of screen type and hole size depends on the seed (variety and condition) to be cleaned. Two very similar screens may produce very different results in the quality of seed cleaning, depending on the individual lot. Different seed lots - even of the same variety - may present major differences in terms of size of crop seed, impurities and weed seeds. Therefore, select a specific adapted set of screens for each seed lot.

Screens do not last forever: over time, they bend and the flow of seed becomes concentrated towards the middle. This results in several layers of seed at the centre of the screen and little or none at the edges. Uneven distribution of seed on the screen hinders the removal of impurities and the cleaning process is less efficient. Replace worn and damaged screens.

Screen types (slotted holes, round holes and wire mesh)

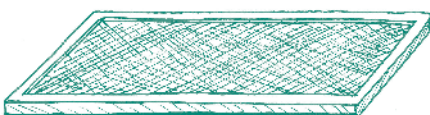
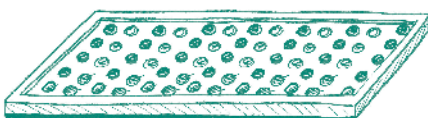
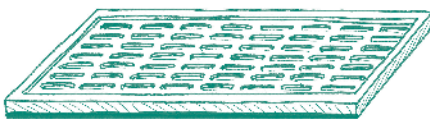

Combinations of screens with different hole types may be used in a single operation, for example: for wheat seed, top screen with round holes (diameter ≤ 6.00 mm) and bottom screen with slotted holes (width ≥ 2.2 mm). The table below provides a general guide for the most common sizes of holes for selected crops. These are approximate values, because agricultural conditions and variety types vary between countries.

3

Most common screen hole sizes for cleaning selected crops

(Units: mm diameter in round holes and mm width in slotted holes)

Crop	Top screen			Grading screen		
	From	To	Hole type	From	To	Hole type
Alfalfa	1.75	2	round	0.5	0.6	slotted
Barley	5.25	5.6	round	2.1	2.3	slotted
Bean	5.5	7	slotted	3	4	round
Clover	1.5	1.8	round	0.5	1.2	slotted
Maize (white dent)	8	11	round	7.5 3.3	7 3.7	round slotted
Maize (flint/semi-dent)	7	9	round	5 3	5.5 3.5	round slotted
Oats	3	3.5	slotted	1.4	1.6	slotted
Rice (long grain)	5 2.5	5.5 2.8	round slotted	1.6	1.9	slotted
Sorghum	4	4.5	round	3 2.2	3.3 2.3	round slotted
Sorghum (sudan)	3	4	round	2.2 1.4	2.3 1.6	round slotted
Soybean	10	9	round	5.5 3.4	6.3 3.6	round slotted
Sunflower	5.5	7.5	round	2.3	2.6	slotted
Wheat	4.5	5	round	2.1	2.3	slotted

notes

Types of air-screen cleaners

Most air-screen cleaners have flat screens, but rotary air-screen cleaners use cylindrical screens. When selecting an air-screen cleaner (size and type), consider:

- power requirements;
- quantity and kind of seed; and
- ease of cleaning the equipment.

Flat screens are cheaper than cylindrical and are easier to clean between seed lots. On the other hand, cylindrical screens have the advantage of a bigger throughput in kg/hour despite their smaller size.

notes

Flat air-screen cleaners

The flat air-screen cleaner comprises the following main parts:

- **Inlet hopper** - situated on top of the cleaner, it holds the incoming material and provides a uniform and steady flow of raw seed into the cleaner. Some cleaners have an adjustable gate below the inlet hopper to regulate the flow of seed.
- **Feed roller** - mounted below the inlet hopper, it feeds the seed into the cleaner. The feed roller also shakes and mixes the incoming seed to ensure a gradual and uniform distribution of seed across the entire width of the uppermost screen.
- **Screen boat** - compartment in which the screens are mounted. Screens with large holes are placed above, those with small holes below. The first screen is usually the scalping screen; it discharges below onto two screens, one beneath the other. Under the bottom screen, there is usually a blank "screen" for collecting fine particles (e.g. sand and soil). Some cleaners are fitted with brushes to clean or unblock screens clogged with seeds. In others, there are bouncing rubber balls below the screens to prevent seeds becoming lodged in the perforations. The screen boat is connected to a drive mechanism, which provides an oscillating motion.
- **Discharge spout** - at the end of each screen or set of screens, a discharge channel collects and delivers material by gravity or screw conveyor to an outlet. The material passes through the discharge spout and is collected in a bag.

Flat air-screen cleaner

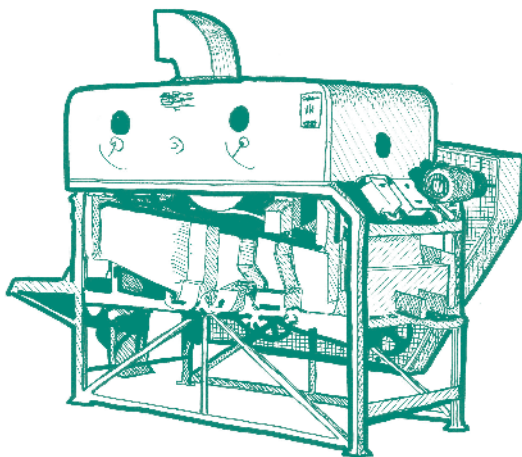

Cleaner with elevator feed

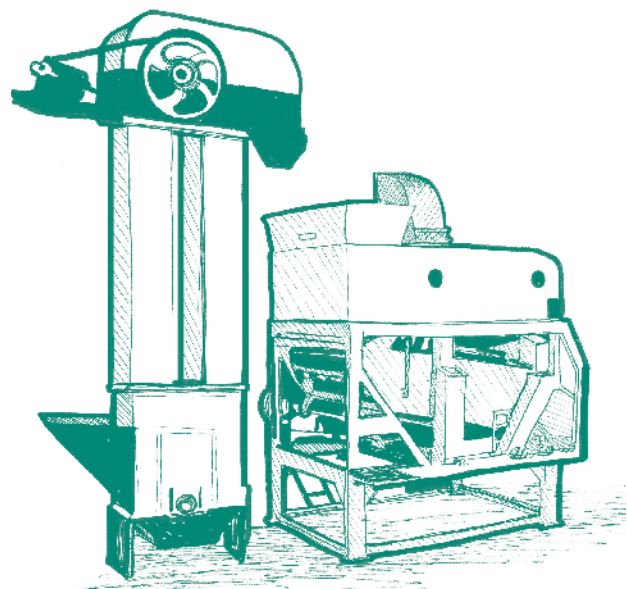

notes

Operation steps:

- Raw seed is fed into the inlet hopper, from where it falls into the cleaner.
- Fanned air blows light particles out of the seed stream.
- Seed enters and tumbles gently around the cylinder.
- Seed is separated into various fractions of different sizes.
- Seed falls through the cylinder perforations into the hoppers below the respective sections of the cylinder.
- Cleaned seed is bagged or conveyed for further processing.
- Largest particles or impurities exit at the end of the cylinder assembly into a collecting spout.

For good rotary air-screen cleaner performance:

- Adjust the seed flow rate.
- Regulate the airflow rate.
- Regulate the rotation speed of the cylinder and the angle (they influence both throughput and cleaning action).

Rotary screen cleaner

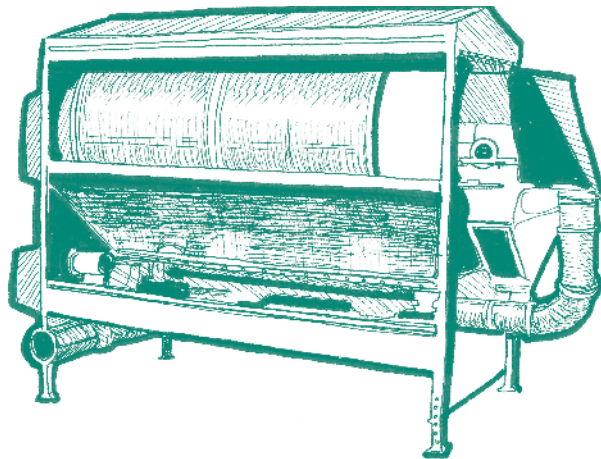

Seed flow through rotary screen cleaner

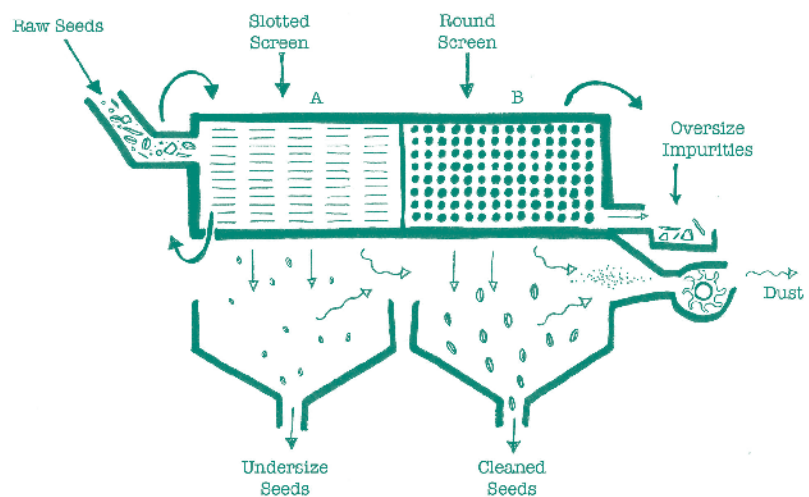

notes

is fitted with an overlaying steel grill. The sides of the hopper must be at an angle of $\geq 35^\circ$ to ensure that the seed flows from the hopper into the conveyor by gravity. The capacity regulation slide controls the flow. The intake hopper is connected to the inlet hopper of the bucket elevator by sections of ductwork. The opening in the steel grill allows seeds to fall through, while large objects (e.g. straw, stones and other foreign materials) are retained. The steel grill also ensures that no empty sacks fall into the machinery.

Adjustment and maintenance of intake hoppers

The intake hopper requires continuous and careful maintenance. Routine checks and inspections, accompanied by any necessary action, are essential during operation:

- Remove any material that may cause blockages, particularly at the grill, in order to maintain the smooth flow of seed into the intake elevator or pneumatic lift.
- Repair walls for wear and tear, with particular attention to the joints and grill, in order to prevent leakage of seed.

Bucket elevator system

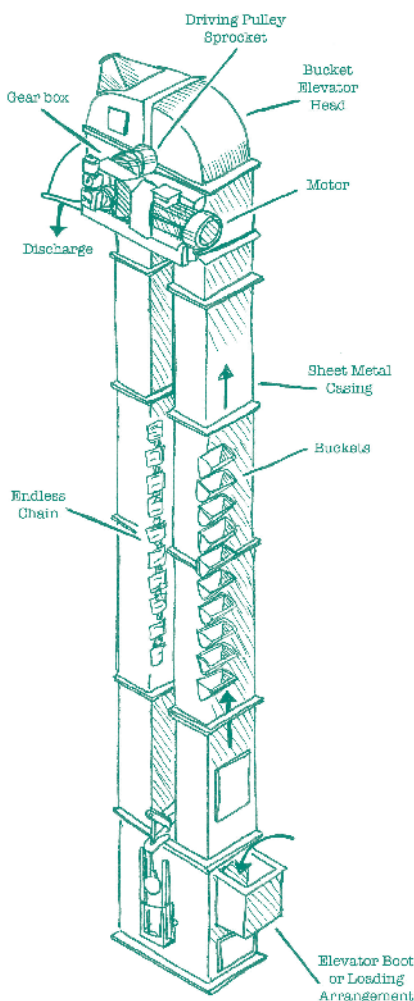

Bucket elevator

The bucket elevator lifts seed vertically into other machines in the processing line. It is in three sections:

- **Boot** - lower section - comprising steel case, pulley with shaft mounted in bearings, belt tension device, inlet hopper and capacity regulation slide. The boot is secured to the floor with bolts. At the bottom, there is usually a sliding screen that can be removed for cleaning to remove residual materials.
- **Legs** - middle section - usually rectangular in cross-section, self-supporting and mounted on the boot. Parts of the legs may be fitted with inspection windows and connected to the dust collection system.
- **Head** - top section - mounted on top of the legs and comprising steel case, drive pulley with a shaft mounted in bearings, bracket for motor and power transmission arrangements, throat plate and discharge chute.

Inside the bucket elevator case, a rubberized belt passes continuously over the two pulleys and through the legs. Buckets or cups made of pressed or welded steel or moulded plastic are fastened to the belt using special nuts and bolts.

The bucket elevator is self-supporting. Nevertheless, it is often fixed with brackets to the floors, walls and roof to ensure that the elevator stays vertical and stable during operation.

Operation steps:

- Seed is fed into the inlet hopper of the boot.
- Cups on moving belt scoop seed and transport it upwards.
- Cups empty seed as the belt moves around the top drive pulley.
- Centrifugal effect directs the seed into the discharge chute and finally to its destination.

3

notes

The capacity of the bucket elevator depends on the belt speed, cup shape and belt spacing, as well as the position of the inlet hopper. To ensure efficient seed processing, monitor and adjust the speed of the bucket elevator.

Adjustment and maintenance of bucket elevator

Proper maintenance of the bucket elevator is essential to maintain carrying capacity. Lack of care and repair can result in damaged buckets, a stretched and damaged belt, blocked inlets or overloaded electric motor, resulting in operational problems and eventual breakdown.

The following maintenance activities are **essential** for bucket elevators:

Elevator boot:

- Carry out a daily inspection and cleanliness check. Remove seed, dust and chaff residues from the boot.
- Inspect and check for dust and seed leakages in the boot during operation.
- Periodically inspect for corrosion and wear on the boot housing, pulley, capacity regulation slide and inlet hopper. Check for missing nuts and bolts.
- Periodically check the condition and functioning of the belt tension device and bearings. Lubricate according to the manufacturer's recommendations.

Elevator legs:

- Inspect regularly and check for cleanliness, dust and seed leakages.
- Check for wear of the casing, and for missing nuts and bolts on the elevator legs.

Elevator head:

- Periodically inspect and check for cleanliness, especially of the drive station.
- Periodically inspect the head housing and discharge chute. Check for missing nuts and bolts.
- Inspect and check the condition of the drive pulley and bearings. Lubricate according to the manufacturer's recommendations.
- Inspect and check the condition of the motor and the power transmission system: gearbox, oil/lubricant levels and leakages, couplings, belt drives.

Elevator belt:

- Carry out periodic inspections.
- Check for wear and tear, verify the belt tension, and check whether there is slippage or it is off-centre.

Elevator buckets:

- Carry out periodic inspections.
- Check for wear and tear, loose or missing buckets, bolts and washers, and deformed buckets.

Parts of elevator boot

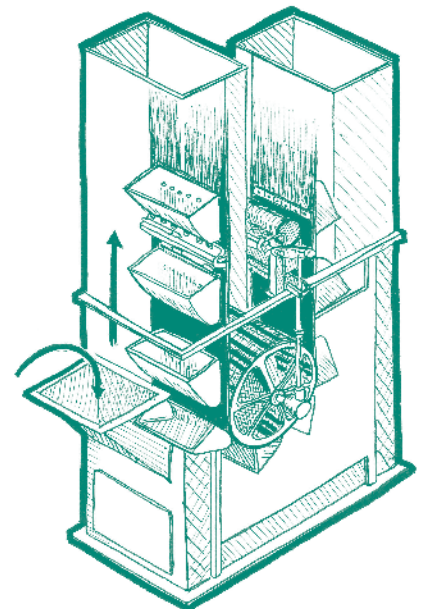

Parts of elevator head

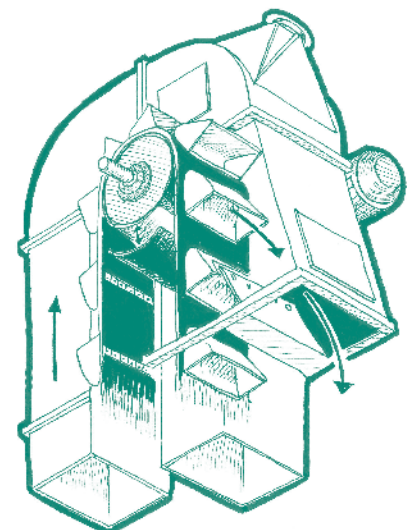

notes

Elevator support structure:

- Carry out periodic inspections.
- Check that the supports, access ladders, service platforms and guard rails are intact and properly secured.

Safety devices:

- Inspect regularly any safety features, including backstops, speed guard, explosion relief panel and misalignment switches.
- At the end of the season, thoroughly clean the entire bucket elevator, inspect and check for worn, broken or missing components. Source the spare parts, replace and repair. Service the machine to keep it in good working order ready for the subsequent season.

Holding bins

Holding bins – buffer bins, surge bins and bagging bins – regulate the flow of seed in the conveying and handling system. Each bin is positioned in front of the relevant piece of equipment (e.g. cleaner, gravity separator, seed treater, in-line process scales and bagging scales).

Hopper bins are usually rectangular in cross-section; a self-emptying hopper at the bottom is inclined at an angle of $\geq 45^\circ$. Some bins are equipped with sight glasses, slide gates, level sensors and flanged air vent connections to either cloth filters or central dust collection systems.

Adjustment and maintenance of holding bins

Holding bins require little maintenance if fabricated from the right gauge of metal sheet. Nevertheless, it is important to inspect:

- sidewalls for wear on the hopper sides;
- slide gate for general condition and leakage;
- air escape vents - clean the filter cloth and adjust the butterfly valve; and
- level sensor for general working condition.

Ducting

The various pieces of equipment in the processing line are connected by pipe-work comprising ducts, chutes or spouts. There are two basic layouts:

- one machine placed on top of the other, seed flowing by gravity through short connections; or
- machines situated on the same floor, seed carried by bucket elevators from one machine to the next, connected via ducting.

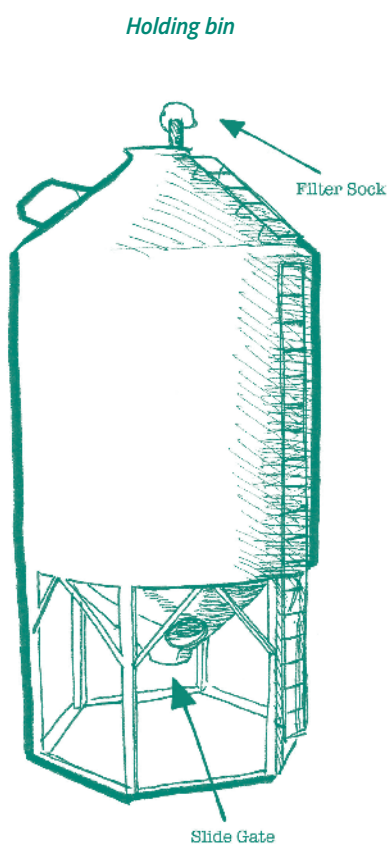

3

Ducting is usually in the form of straight pipe pieces, bends, elbows, junction boxes, valves and diverters. The recommended slope of ductwork is 35–45° to enable seed to flow by the force of gravity. The ducting components are assembled using clips, clamps or bolts. Some ducts are fitted with windows, removable lids or slides to permit inspection during processing.

Adjustment and maintenance of ducting

The ductwork requires continuous and ongoing maintenance during operation of the machinery.

- Inspect ductwork and check for wear, seed leakages and dust - especially at bends, joints and diverters, and on the underside of the ducts.
- Repair slight damage by welding or touch-painting; replace seriously worn ducts.
- Rotate pipes through ¼ turn once a year to evenly distribute the wear on ductwork.
- Line ducts of rectangular cross-section with a non-wear nylon plate, especially when handling highly abrasive products (e.g. maize and paddy).
- At the end of the season, thoroughly inspect and check for worn or broken ducting. Source the spare parts and replace, ready for the subsequent season.

notes

Various parts of the ducting system

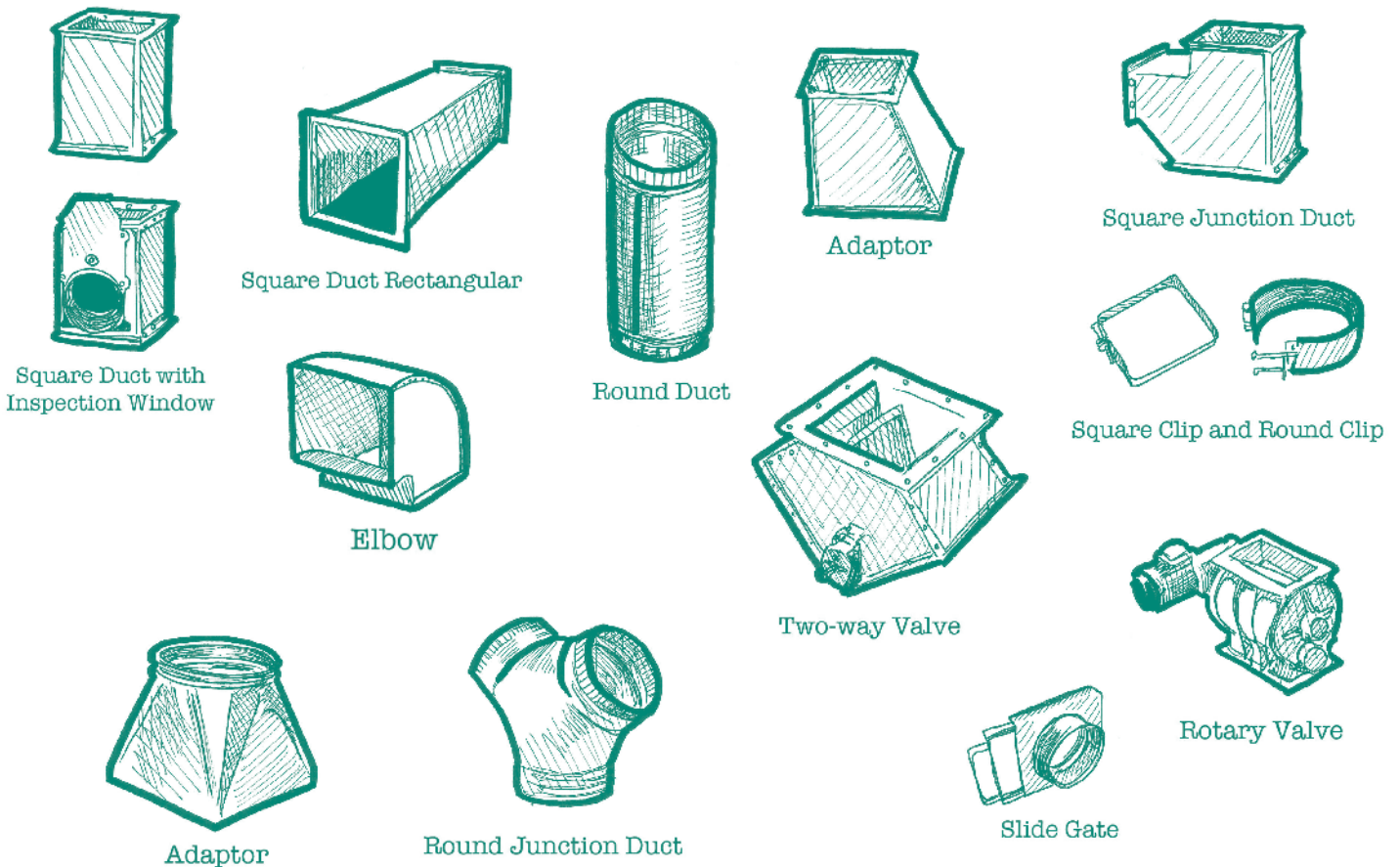

④

Fine cleaning and grading

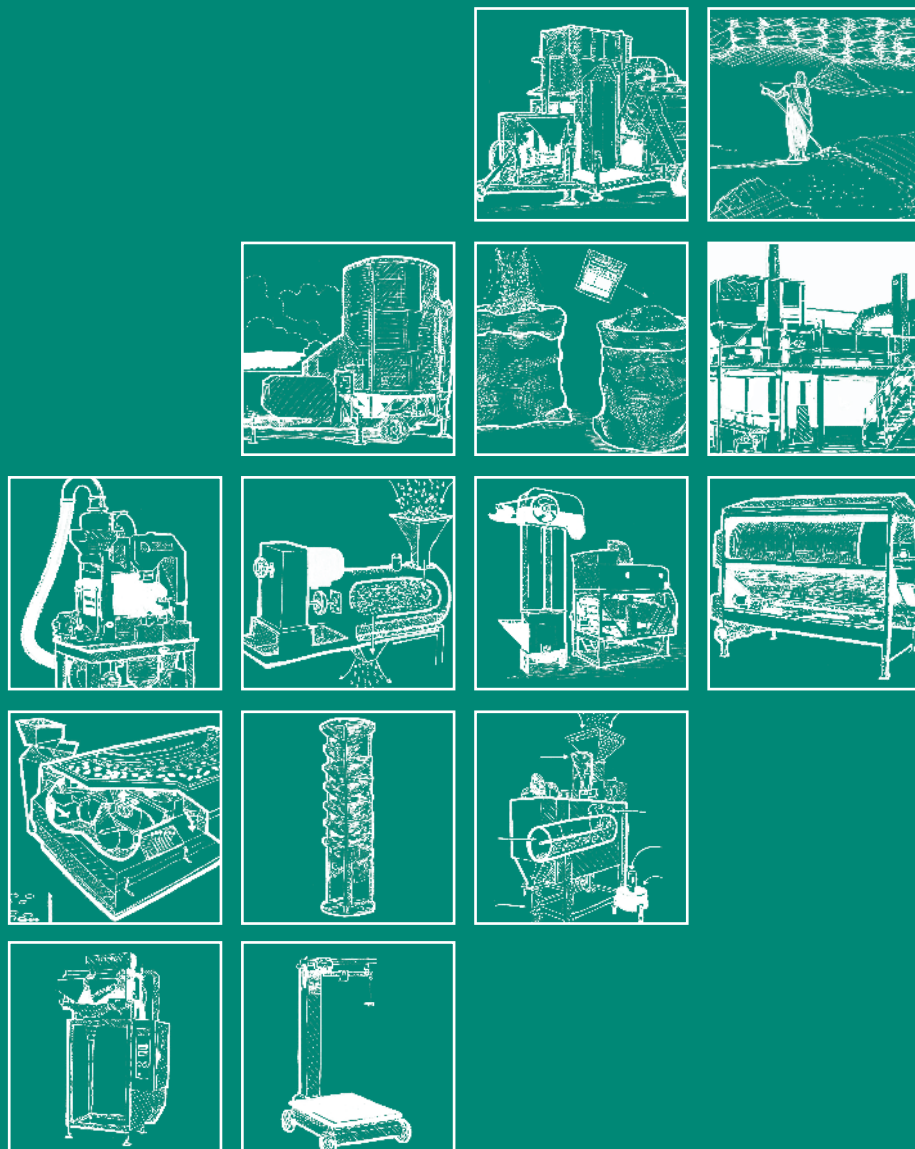

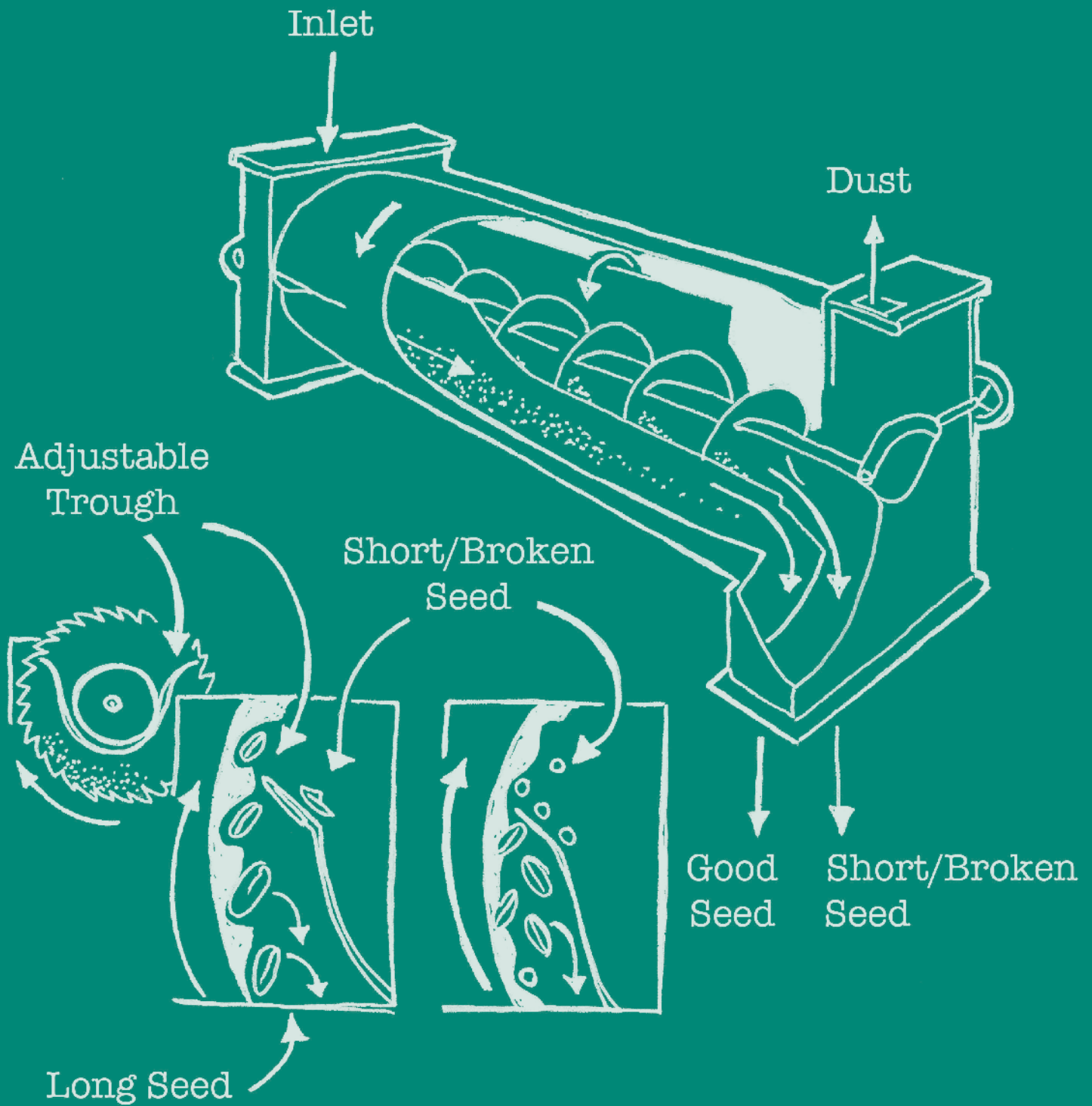

Operation of indented cylinder

notes

Different crop seeds require different sizes of mesh wire on the deck: coarse, medium and fine mesh. Ensure that the gravity separator is delivered with screens appropriate for the crop seeds to be handled.

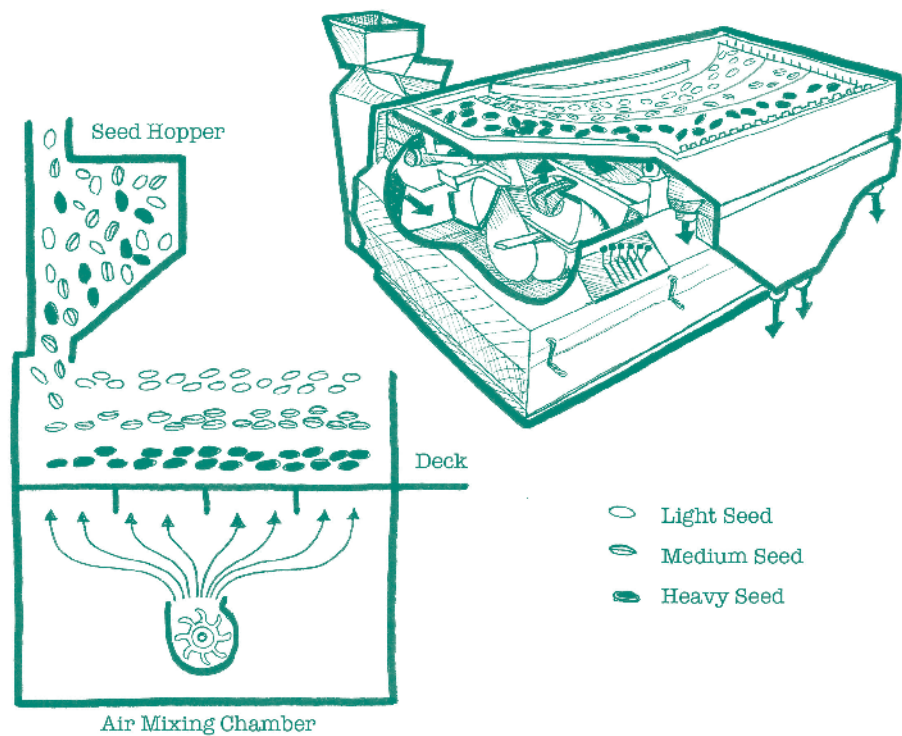
Gravity separator

OTHER TYPES OF EQUIPMENT

The principal pieces of equipment in a seed-processing plant are described above. Other specialized types of equipment are outlined below.

Spiral separator

The spiral separator separates seeds according to their ability to roll. It was originally developed to remove unwanted particles from soybean seeds, but is now used for other crops with spherical seeds (e.g. brassicas - cabbage family).

The machine comprises a column with a spiral slide that has a double bottom. The seed is loaded on top of the slide and rolls down. Perfectly spherical seeds roll down faster, reach the edge of the slide and fall into a separating trough.

4

Non-spherical contaminants roll more slowly and remain in the inner slide. The spiral separator separates seed of the highest quality, but it is only suited to species with spherical seeds. Furthermore, it has a low output (kg/hour). When it is used in a seed-processing plant, groups of spiral separators tend to operate separately from the rest of the plant.

notes

Spiral separator

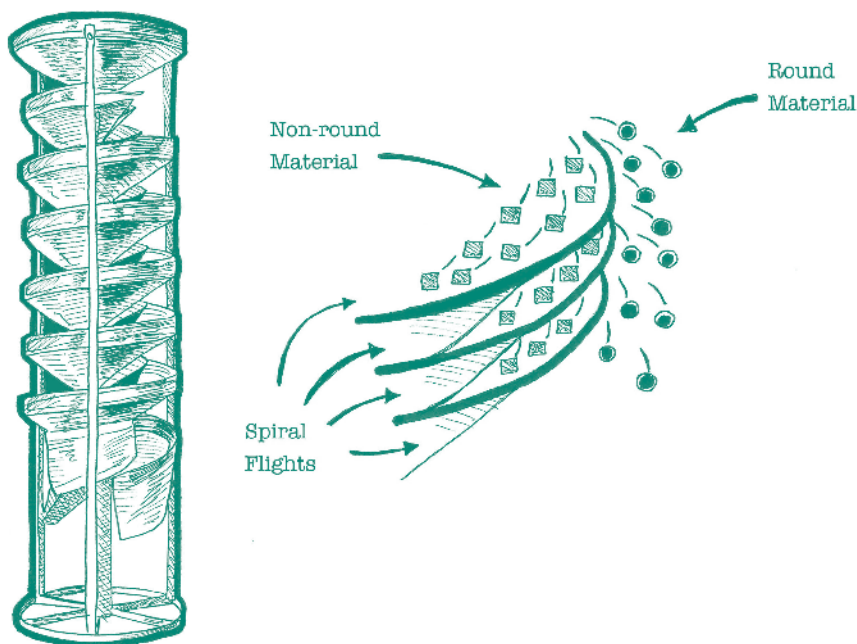

Velvet roller

The velvet roller separates seeds of the same size but differing in roughness. It is useful for forage species, in particular clover: due to the variation in flowering patterns, seed maturity is never homogeneous at harvest and many seeds become wrinkled once dried.

The machine comprises two parallel cylinders, attached together and covered by a special cloth made of natural fibre. The cylinders are slightly inclined and rotate in opposite directions at 0.5-1 revolutions per second.

The seed is placed between the two rotating cylinders and moves down the incline. The rotational movement lifts seeds with sharp edges or rough surfaces and they fall into a collecting bin. The collection system is divided into sections, separating seeds with different degrees of surface roughness.

notes

The velvet roller is one of the few machines capable of separating clover or alfalfa seeds from seeds of the weed known as dodder (*Cuscuta* spp.). However, its output is low, and there is normally a battery of cylinders in one unit (10–12 pairs of cylinders) located apart from the rest of the processing line.

Disc separator

The disc separator - like the indented cylinder - separates seeds by length. It has a very high level of precision, but its throughput (kg/hour) is significantly lower than that of the indented cylinder.

The machine comprises a set of discs arranged vertically on a central shaft 5–10 cm apart. Each disc is fitted with pockets that collect short seeds as the disc rotates. Compared with the indented cylinder, in which the seeds are lifted around the curve of the cylinder, the disc separator lifts short seeds with a perfect vertical movement, resulting in greater precision.

Electromagnetic separator

The electromagnetic separator detects differences in the evenness of the surface and the presence of gaps in the testa. It is a sophisticated item of equipment with high operating costs and is only used for very fine cleaning of expensive seed.

The machine comprises a seed hopper connected to a device that pours iron powder into the batch of seed. Iron dust penetrates any gaps in the testa of the seed and sticks to seeds with a rough surface. The seed is then poured onto a rotating electrically magnetized metallic drum. The seeds charged with iron powder stick to the drum and remain there longer than seeds not carrying iron powder. Consequently, the seeds fall into different collection bins.

Electromagnetic separator

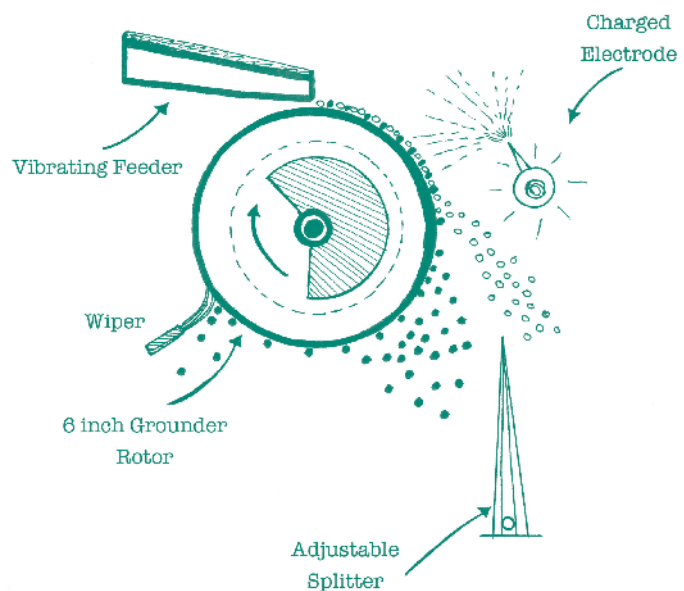

4

Colour sorting machine

The colour-sorting machine – or optical sorting machine – is a sophisticated piece of equipment that separates seeds according to colour or light reflection. The seed is fed into a hopper on top of the machine and guided into thin lines or channels of seed that pass through a dark chamber. A special light bulb illuminates the seed flow and reads the colour of individual seeds. When an impurity is detected, a shot of high-pressed air diverts it from the seed flow.

Colour-sorting machines are expensive; they have a relatively low throughput (kg/hour) with high operational costs, including the replacement cost of light bulbs. Therefore, they are generally used for processing high-value seeds and legumes. The most recent versions are equipped for digital image analysing and they separate seeds with any significant colour differences within the seed lot.

notes

Color sorting machine

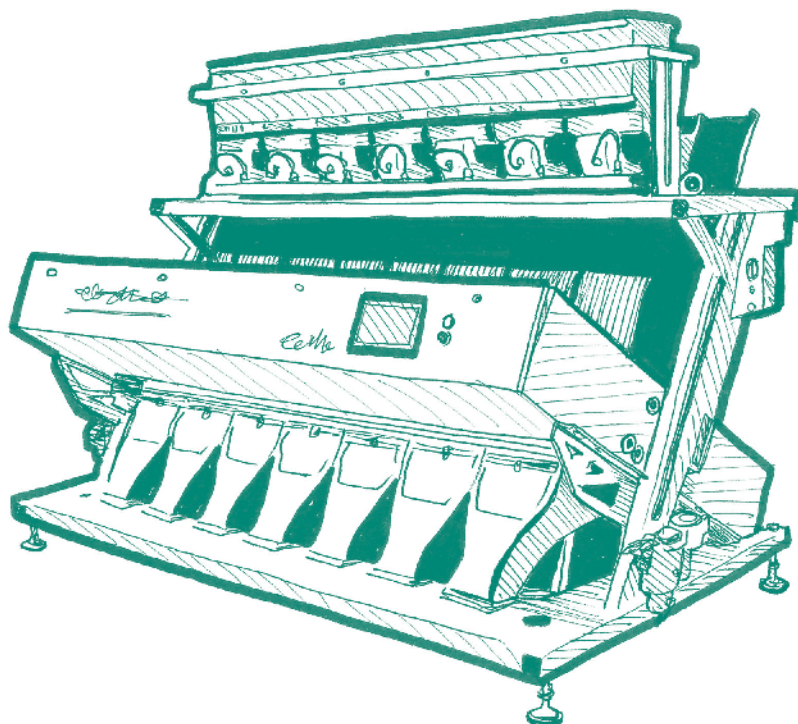

notes

EXERCISES AND DISCUSSION POINTS

1. On inspection, a wheat seed lot cleaned on an air-screen cleaner is found to contain unacceptable limits of impurities: broken wheat seeds; insect- and weather-damaged wheat grains; maize, oat and barley seeds; rotten wheat seeds; and fine chaff and sand. Discuss which seed cleaning and grading equipment you would use to remove these impurities.
2. Why are the indented cylinder and gravity separator located towards the end of the seed-processing line and not at the beginning?
3. The machine operator in a seed-processing plant has adjusted the gravity separator to clean wheat seed; the machine is doing a fine job. The operator decides to make the adjustments listed below. Indicate in each case what effect the adjustment will have on the quality of separation.
 - Doubling the feed rate
 - Halving the feed rate

⑤ Seed treatment, packaging and labelling

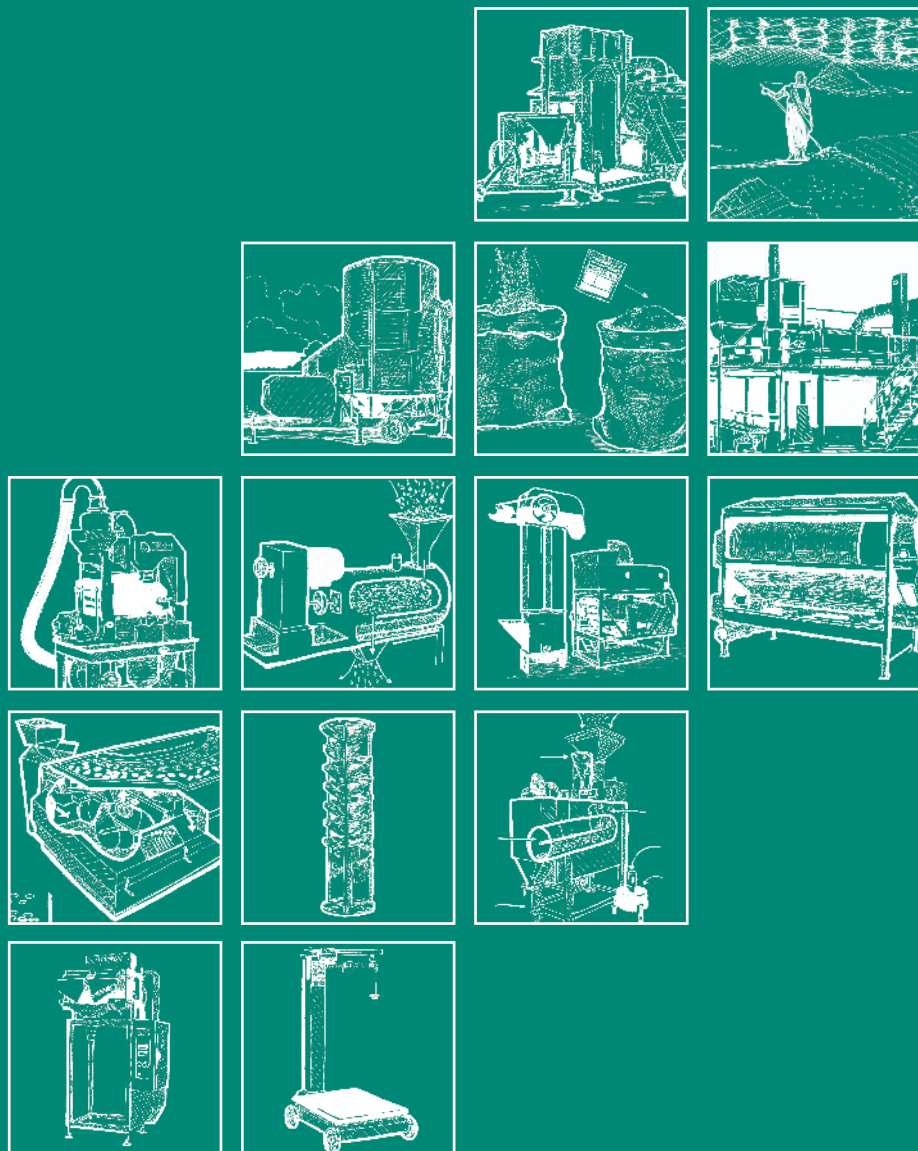

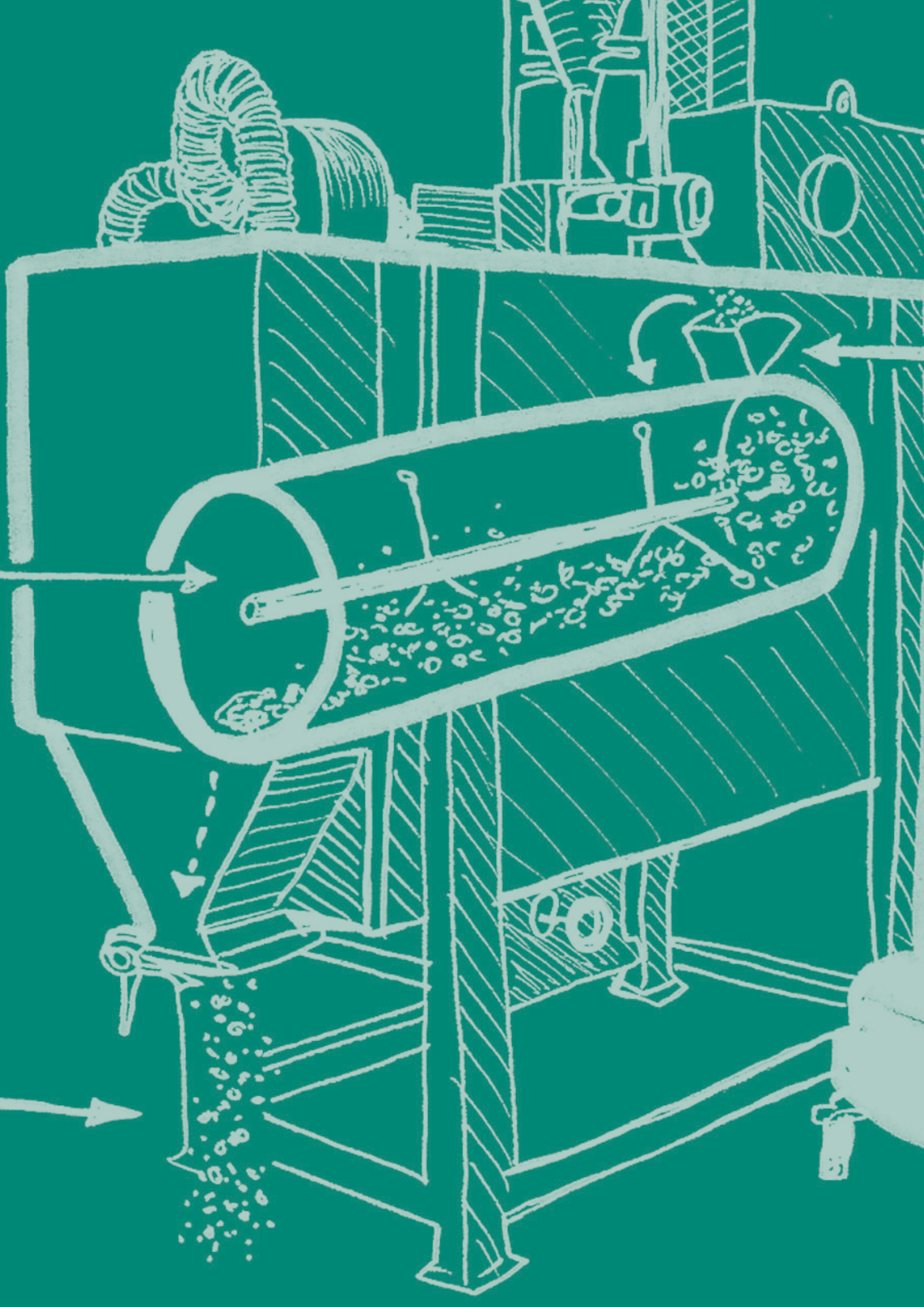

Seed treatment, packaging and labelling



notes

Seed treatment is the application of suitable products to the seed in order to **protect it against attack by insects or disease**, both during storage and at seedling stage in the field. Treatment products may be insecticides, fungicides or both, and they can be applied as dust, liquid or slurry. The principal objective is to thoroughly coat the seed with the correct quantity of product. Seed treatment can also involve **changing or standardizing the shape or size** of the seed; in such cases, inert matter is added - a process known as coating or pelleting.

BENEFITS OF SEED TREATMENT

- Protection - of seed - against insect attack during storage.
- Protection - of seeds **and** seedlings - against attack by soil insects; by soil organisms causing disease; and by other pests (e.g. birds and rodents).
- Control of the spread of plant diseases.
- Improved germination and crop yields

PRECAUTIONS IN SEED TREATMENT

Although there are significant potential benefits, **seed treatment must only be used when necessary**. Careful handling is fundamental, because the chemicals may be dangerous to human health. Seed treatment is basically an agronomic issue: faced with a serious pest or disease threat, a simple seed treatment has a potentially dramatic effect on seedling establishment; this may be a good reason for farmers to buy the seed. On the other hand, the threat from insects and diseases may not be serious enough to justify the use of chemicals - from both a health and an economic point of view. Use of untreated seed may often be the better option.

METHOD OF CHEMICAL APPLICATION

- **Dusts** - dry powder chemicals mechanically applied to the seed. Seed coverage is not uniform and the chemical tends to drift or slide off the seed. Dusts involve the highest level of danger in the processing plant; they float in the air and operators must wear proper masks to avoid inhalation.
- **Liquids** - true solutions of the chemical dissolved in water. Seed coverage is uniform.
- **Slurries** - mixtures of water and wettable powders or grains. They are purchased already mixed or can be prepared just before application. Seed coverage is thorough and uniform.

notes

SEED TREATMENT EQUIPMENT

There are many types of equipment for seed treatment, from simple tools to sophisticated electronically controlled devices, for example, homemade drums, simple grain augers, and various designs and models of seed treaters.

A seed treater is normally incorporated in the processing line, with an in-built bypass system. Ducting connects the machinery positioned before and after the treater, so that seed not requiring treatment can skip this stage. A commercial seed treater usually comprises three main components: mixing tank, treater head and coating chamber.

- **Mixing tank** - used for mixing the chemical with water to form a liquid or slurry. A stirrer mixes and agitates the mixture so that it does not settle. A pump recirculates the liquid chemical and pumps it to the treater head.
- **Treater head** - comprising weighing pan, flow gate, counterweights, tripping mechanism, chain/belt with slurry cups or rocker arm with cups, and spray nozzles. The weighing pan assembly (also referred to as metering system and incorporating flow gate and counterweight) deposits a specific weight of seed in the coating chamber as the incoming seed trips the weighing pan. The metering system simultaneously actuates the slurry cups on the belt or rocker arm, and they discharge the correct dosage of slurry or liquid onto the moving seed in the coating chamber. When dust is applied, the treater head is equipped with a powder measuring system in the form of vibrating pipes or cups.

Components of a seed treater

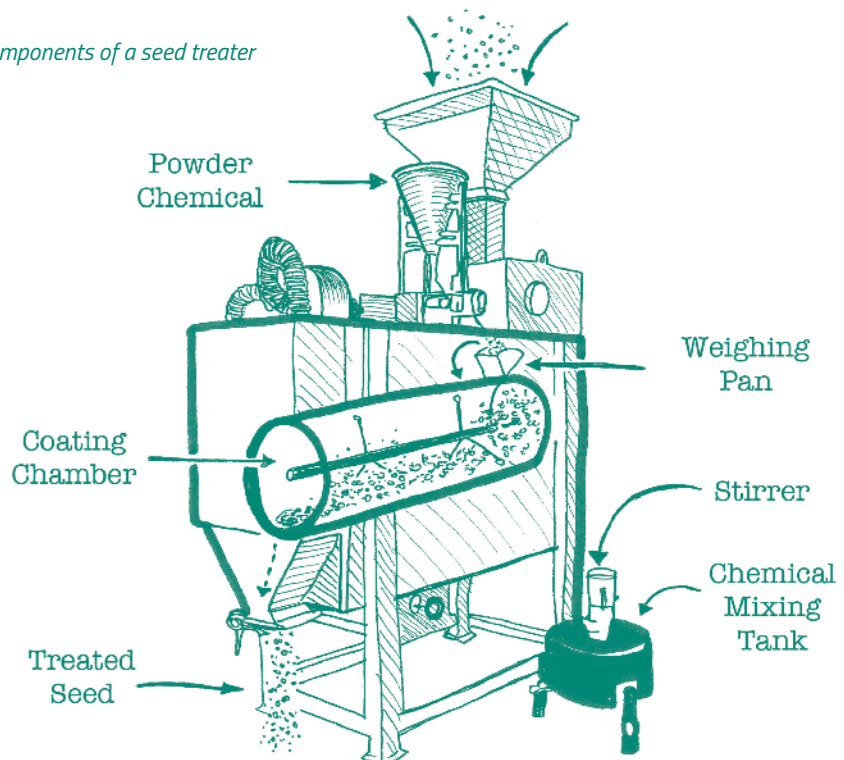

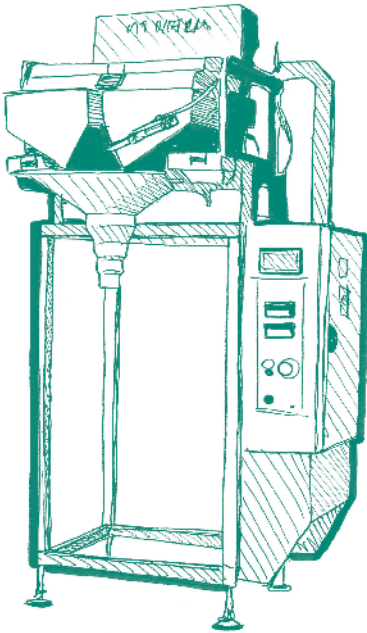
Automatic weighing scale

For **certified seed** lots, the label is printed and delivered by the certifying authority. The seed enterprise may sometimes have the authority to print its own labels under the supervision of the certifying agency. In some countries, a seed enterprise can be accredited to produce certified seed and it prints its own label.

Some countries permit the category: **“truthfully labelled seed”**. The enterprise has full legal responsibility for the information that appears on the label.

Labels should normally include the following minimum information:

- Germination
- Date of germination test
- Purity
- Weed content (optional)
- Name and address of seed enterprise (not always obligatory; processor/company code may be sufficient)
- Seed category
- Species and variety
- Seed lot number (for traceability)
- Seed treatment, product applied and dose

PACKAGING

Once cleaned (and treated if necessary), the seed is sent for packaging; it is placed in new bags, which are weighed and sewn. For seed not treated by an inline seed treader, a sachet containing the treatment chemical may be scattered on the seed in the weighed bag, which is then sewn. Bags are often preprinted with details indicating name of seed enterprise (and logo), seed class and net weight, plus a poison warning if the seed has been treated with chemical. Further information - variety, lot number and test date - is included on the label as appropriate. Packaging equipment comprises weighing scales and bag stitchers.

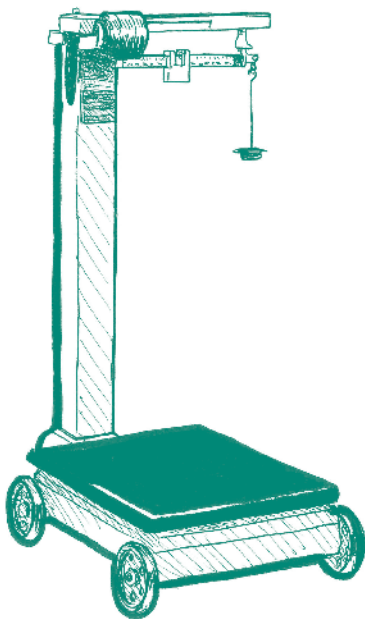
Weighing scale

Weighing scale

Weighing must be accurate, as there is a legal responsibility for the weight stated on the label when seed is marketed. Seed or other material is weighed at reception, during processing and at bagging. Weighing scales may be electronic or manual, digital or analogue (dial). A popular model is a moveable scale comprising a platform on which the bag is placed, a supporting bar for the bag and a graduated beam with a suspension hook for weights. The platform rests on four castor wheels. A variation of the same scale has a dial instead of the graduated beam.

5

Handle scales with care during use to ensure consistently accurate measurements and readings. Service regularly and contact the manufacturer's representative or an approved technician for repairs as necessary.

Adjustment and maintenance of weighing scales

The following maintenance procedures are essential:

- Ensure that the weighing scale is checked, approved and stamped by the relevant government agency.
- Ensure that the weighing scale is checked, serviced and repaired by approved technicians.
- Regularly use the test-weight that comes with the scale to ensure that the readings are accurate and consistent.
- Keep the weighing scales clean and tidy.
- Dust off any objects that obstruct scales and may result in erroneous readings.
- Ensure that the weighing scale rests on a perfectly horizontal floor.

Bag stitching machine

This machine stitches or closes bags once they are full. Most stitchers are light-weight, hand-held devices with a strap suspension system. They feature single/double-thread chain stitching with an automatic thread-cutting mechanism. Suspend the sewing machine with a cord and spring for easier manipulation.

Adjustment and maintenance of sewing machines

The following maintenance procedures are essential:

- Ensure the sewing machine is always clean and tidy.
- Lubricate according to the manufacturer's instructions. Pay attention to the type of oil: use only recommended oils.
- Ensure that the machine is regularly serviced by the manufacturer's representative.

STACKING PROCESSED SEED

Once sewn, take the bags to the finished goods store. Place them on wooden pallets and arrange in an orderly pattern to facilitate counting and inspection. Do not exceed the maximum recommended stack size in terms of number of bags and height of the stack. A stack may sometimes constitute one seed lot.

Leave ample space around the stack, between stacks and between the stack and the wall. Small stacks are practical for inspection, counting and fumigation. Label the stack.

notes

Bag stitching machine

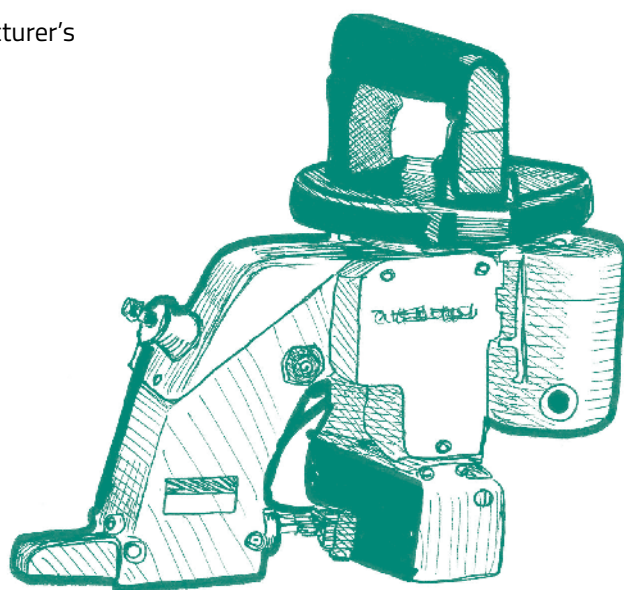

notes

Keep the store dry, clean and tidy at all times. Carry out regular inspections for signs of infestation; fumigate with recommended products as necessary. There may be national regulations imposing a maximum weight for seed bags; check with the relevant authorities - typically in the ministry of work, health or agriculture. In any case, it is unlikely that an enterprise would pack seed in bags in excess of a liftable weight (e.g. 50 kg).

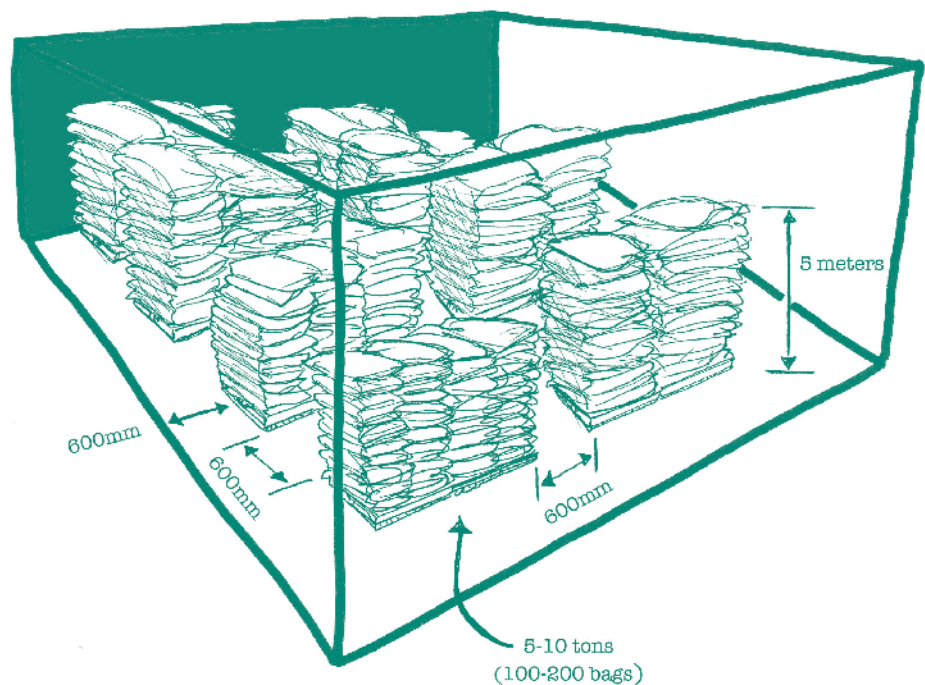
Store with stocks of seed

EXERCISES AND DISCUSSION POINTS

1. How would you ensure that weighing scales perform well and give reliable results in the long term?
2. What are the principle benefits and main harmful effects of seed treatment?
3. What would you do to ensure that processed seed is well stored before being dispatched to the farmer?

⑥

Processing-plant management and general maintenance

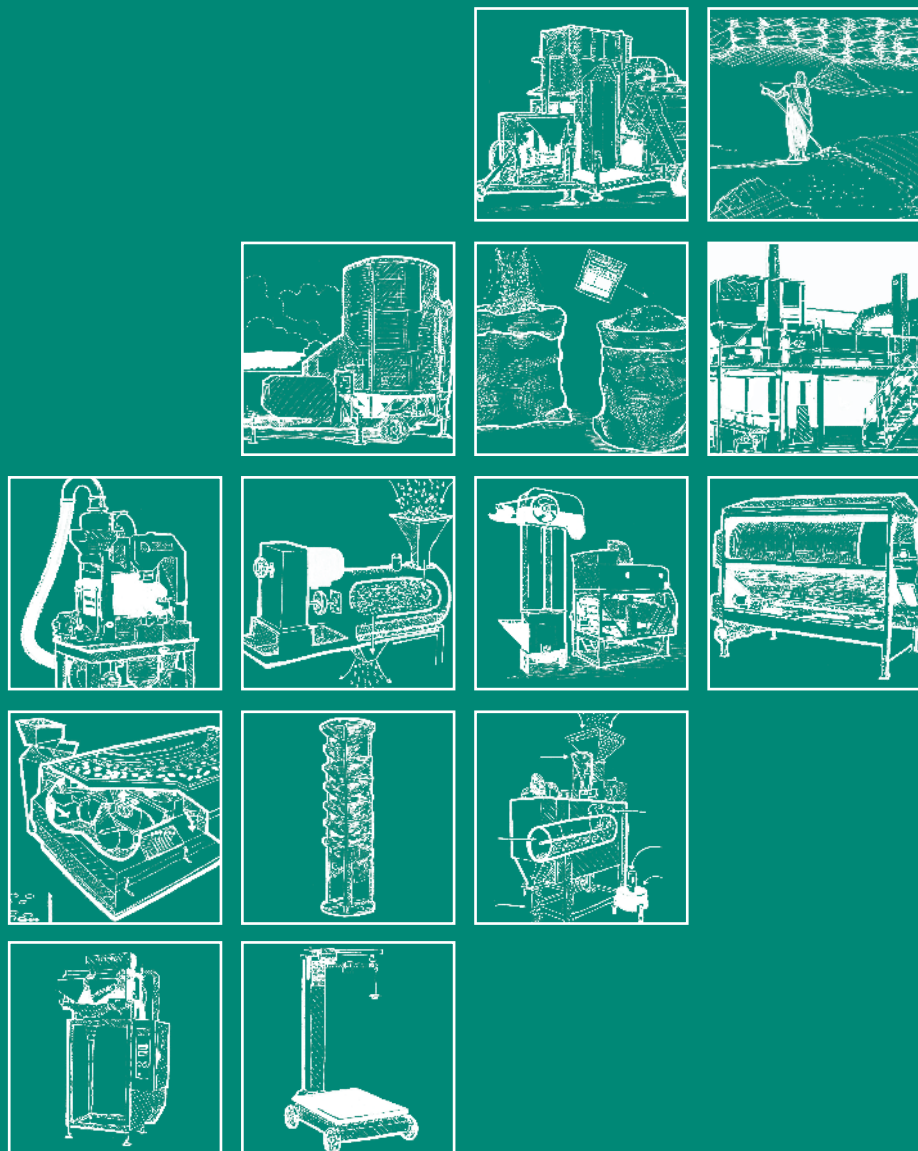

Threshing System

Feeding
Chute

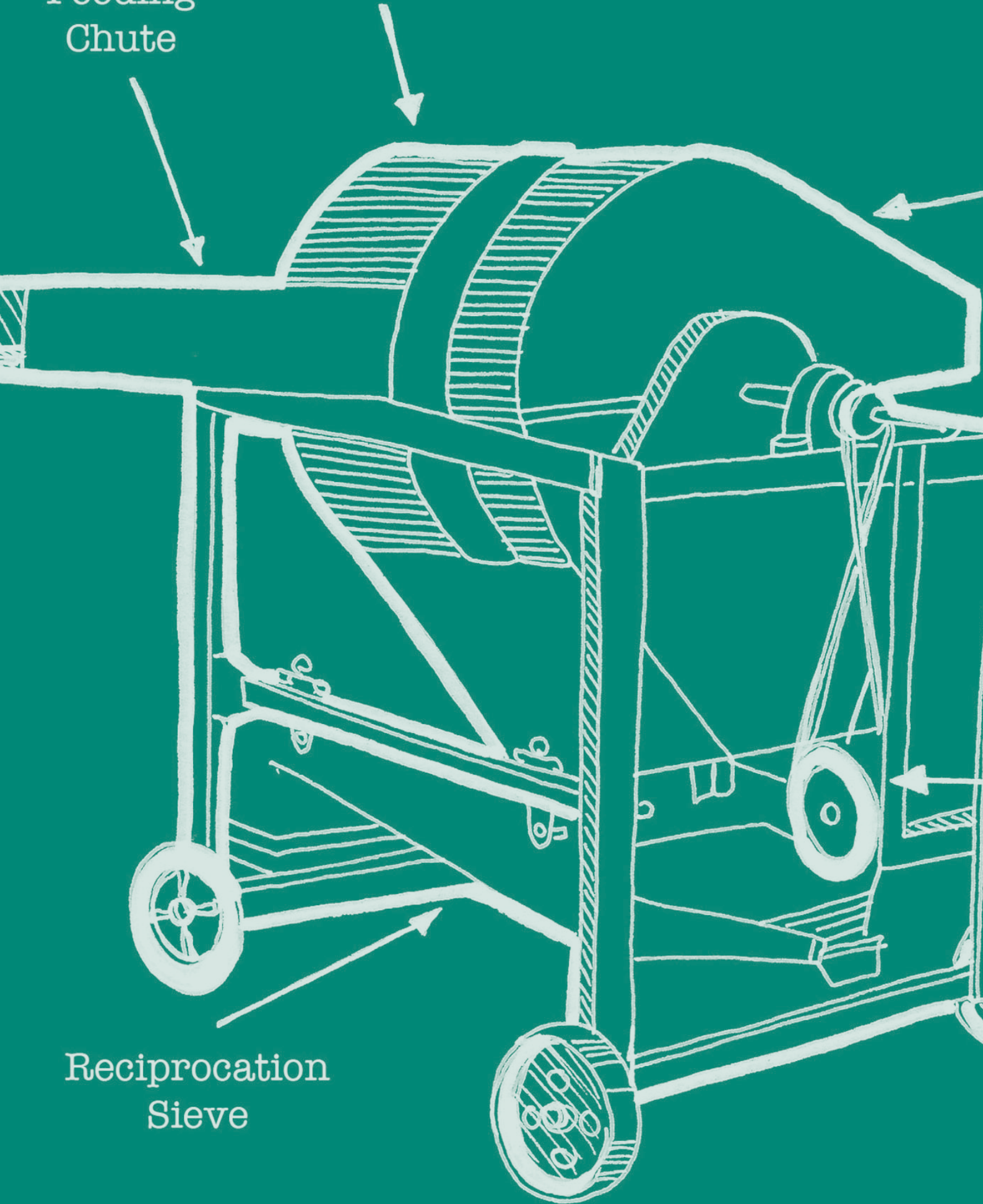

Reciprocation
Sieve

Processing-plant management and general maintenance

6

notes

Operation involves making a piece of machinery or equipment perform a certain mechanical function. **Good operation** means making equipment work efficiently while ensuring that no harm occurs to the person carrying out the operation or to other persons or property.

Maintenance covers a range of activities that serve to keep a machine or building in **efficient and safe working order**, able to carry out its necessary functions. Maintenance activities include checking, inspection, adjustment, lubrication, repairs, painting, and replacement of worn and broken parts.

BENEFITS OF GOOD OPERATION AND MAINTENANCE

- Extended and problem-free working life
- Reduced downtime, i.e. fewer and shorter periods in which part or all of the plant cannot function due to technical failure, adjustment problems, maintenance works or non-availability of inputs (e.g. spare parts or other materials, labour and power)
- Full-capacity performance
- High quality of processed product
- Reduced risk of safety hazards and accidents
- Reduced production costs due to extended working life of equipment
- Time-use efficiency (carrying out proper maintenance before the processing season).

TYPES OF PROCESSING-PLANT MANAGEMENT AND MAINTENANCE

Routine activities carried out to prevent failure and prolong the working life of the item are known as preventive or **scheduled maintenance**. Activities carried out following equipment breakdown or failure are **corrective maintenance** or repair maintenance. Corrective maintenance often results in loss of production due to downtime. Proper and timely preventive maintenance practices minimize the need for corrective maintenance.

User manuals detail the manufacturer's recommendations with regard to servicing and routine maintenance. It is fundamental to follow these recommendations. Routine management includes an obligatory, thorough and complete clean-out of all the equipment in the seed-processing line using compressed

notes

air before a new seed-processing session begins and when changing from one variety to another. Ensure that no residual impurities and seeds remain in the system. It may be necessary to use compressed air to remove seeds lodged in hidden and difficult-to-reach areas within the machine.

Machine manufacturers normally indicate the expected working life of important pieces of equipment. To plan for eventual replacements, establish a **registry** listing all pieces of equipment and recording:

- daily working time (number of hours);
- spare parts replaced; and
- repairs carried out.

Daily maintenance activities during machine operation include cleaning; checking; adjusting machine parts and components; and tightening loose bolts, nuts and screws. During inspection, the maintenance technician ascertains the condition and functioning status of each machine by looking closely, listening carefully, feeling, smelling and using measuring instruments when necessary. Inspection should take place while the plant is in operation, with the technician moving around the plant, examining individual machines to reveal and identify any problems. Grease and lubricate certain parts of the machines on a daily basis, as recommended in the maintenance manuals.

Weekly maintenance activities involve mainly inspections, adjustments and lubrication; **monthly** maintenance activities include inspections, lubrication and replacement of worn parts.

Seasonal or **annual** maintenance takes place immediately after the end of the season and well before the onset of the new season. It includes a comprehensive and thorough cleaning and inspection of the entire plant; lubrication; replacement of worn and broken parts; painting; and modifications or additions. Once seasonal maintenance is complete, it is possible to order recommended fuels, oils and lubricants, as well as fast-moving spare parts to ensure no supply hold-ups once the new season begins. Avoid delays in seasonal maintenance; it is important to allow time for delivery of ordered parts to ensure that the plant is well serviced in time for operations to begin in the new season.

At the start of the new season, it is important to test run the plant without seed material. Some plants run only in manual mode, others have auto and manual mode options. In any case, select manual mode and test run the individual machines one at a time. During the test run, check the condition of each machine: look, listen, feel and smell, and use specific measuring instruments as required.

On satisfactory completion of the seed-free test runs, introduce the raw seed gradually and adjust the machine capacity by manipulating the various capacity slides to achieve the desired throughput. On completion of the test runs, switch the plant to the preferred mode of operation for normal seed processing.

Maintenance of control panels and electric installation

notes

Some seed-processing plants have individual switches to start each machine manually; other plants have all the switches integrated in one control panel. The control panel oversees and monitors all processing equipment in one place, usually in a special room or section of the plant. Keep the control panel environment clean, well ventilated and free from dust and water. The only items allowed in the control room or near the control panel are those needed by the plant operator for leading and supervising operations.

The electrical power coming into the processing plant – whether from the generator or the mains of the national/city grid – is connected and terminated in the electrical control panel.

The control panel is the source of electric cables for the power supply and machinery controls (e.g. motors, switches and level sensors). There may be push buttons, light indicators, switch handles, buttons, meters, clocks and dials. Some control panels feature flow mimics to indicate the flow of the seed in the plant.

To ensure the electricity supply, provide appropriate service and maintenance of the electrical control panel and the entire electrical installation. A technician specialized in industrial electric installations must carry out the maintenance work. The following maintenance procedures are essential:

- Report any malfunction, however minor, to the supervisor. Operators must be attentive to any unsatisfactory condition of equipment that might disrupt operations. A skilled electrician or trained personnel must deal with any faults in the electrical devices.
- Check at least once a year the electrical control panel, switchboards and cabinets for accumulation of dust in the inner devices. Remove dust with care, brushing and sucking off by vacuum. When closing doors and lids, check that the gasket is in position and sealed properly.
- Inspect regularly electrical motors. Ensure that motors are not covered by bags or buried under rubble. Clean and remove dust. When servicing the motor, make sure the safety switch is off.
- Check on a monthly basis all connections of earth wire with base metal to ensure there are no disconnections. Check that the lightning conductor is properly earthed and supported.
- Inspect regularly electrical cables and check for mechanical and rodent damage. Protect electrical cables from mechanical damage and long exposure to sunlight. Replace damaged cables.
- At the end of the season, inspect the electrical control panel carefully for broken and damaged parts. Source and keep in stock fast-moving electrical spare parts (e.g. contactors, contactor contacts, coils, overload relays, indicator lamps, push buttons, limit switches and level sensors).
- Rationalize the electrical motor ratings and sizes in the plant. Keep in stock one spare electrical motor for every motor rating.
- Ensure that safety fuses are installed separately for each main machine.

notes

Maintenance of generator sets

The electrical power running the machines in the seed-processing plant is supplied either by a diesel generator or by the national or city grid mains.

The diesel generator set comprises two main parts: an engine powered by diesel fuel and a dynamo. The engine turns the dynamo to produce electric power. The electricity generated is wired into the electrical panel for control and distribution to the various machines in the plant.

The generator requires careful maintenance:

- Keep the generator room well covered and protected from the elements. It must be well ventilated and kept clean at all times. Do not use the room as a store for empty bags, rejected grain, scrap parts or similar waste.
- Clean the generator on a daily basis. Inspect the engine and check for oil and fuel leaks.
- Clean thoroughly on a daily basis the radiator (of a water-cooled engine) and the engine cooling fans (of an air-cooled engine).
- Before starting the engine, always check the condition and level of oil and (for a water-cooled engine) the water level in the radiator.
- When the engine is running, inspect continually, check for loose bolts and screws, and be alert to vibrations or unusual sounds.
- Carry out routine service and change the engine oil and oil filters according to the manufacturer's recommendations. Always use new oil filters and the recommended type and grade of oil.
- Always use clean fuel.

Control panel and control panel with mimic

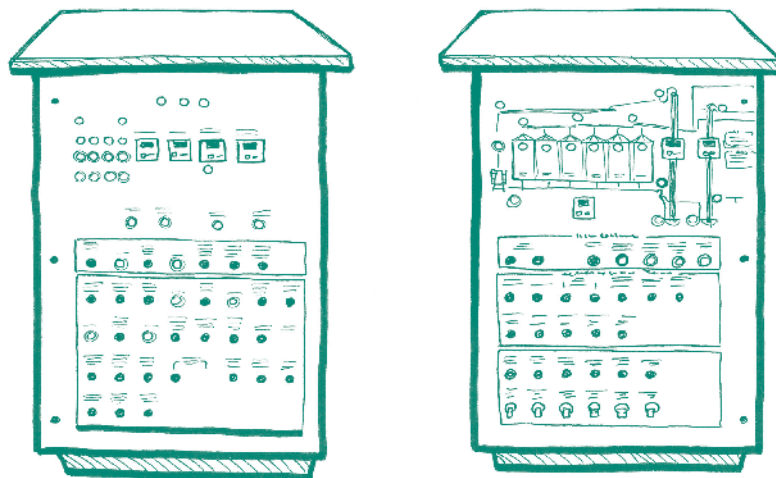

6

- Inspect and check the condition of the batteries. Position batteries on a proper base, preferably wooden, and ensure that the battery terminals are firmly fixed to the starter cables.

notes

SUMMARY

- Carry out **scheduled maintenance** - essential to keep machines in good and efficient working condition and to minimize downtime.
- Perform a **test run** of the seed plant just before a new season begins. Verify the condition and functioning of each machine: look, listen, feel, smell and use measuring instruments. Adjust, lubricate and correct as necessary.
- Carry out **preventive maintenance** during the season according to the manufacturer's recommendations - on a daily or weekly basis, or after a certain number of working hours. Scheduled maintenance helps ensure proper operation of the plant and includes machine inspection; checking, adjusting, adding or changing V-belt drives on the cleaner; lubricating; cleaning air and oil filters; and tightening loose bolts or screws.
- Carry out **corrective maintenance** as required during the season and rectify any breakdowns by repairing broken components or replacing them with new ones. Repair/replacement is necessary for items such as failed bearings, broken V-belts and link belts, burnt motors, broken or worn ducting, and cleaner housing. During the off season, run the plant - especially the generator set - once a week for 10 - 15 minutes.
- Order **spare parts** in time to guarantee delivery well before the next season. To minimize downtime, especially during corrective maintenance, keep a minimum stock of fast-moving spare parts and consumables.

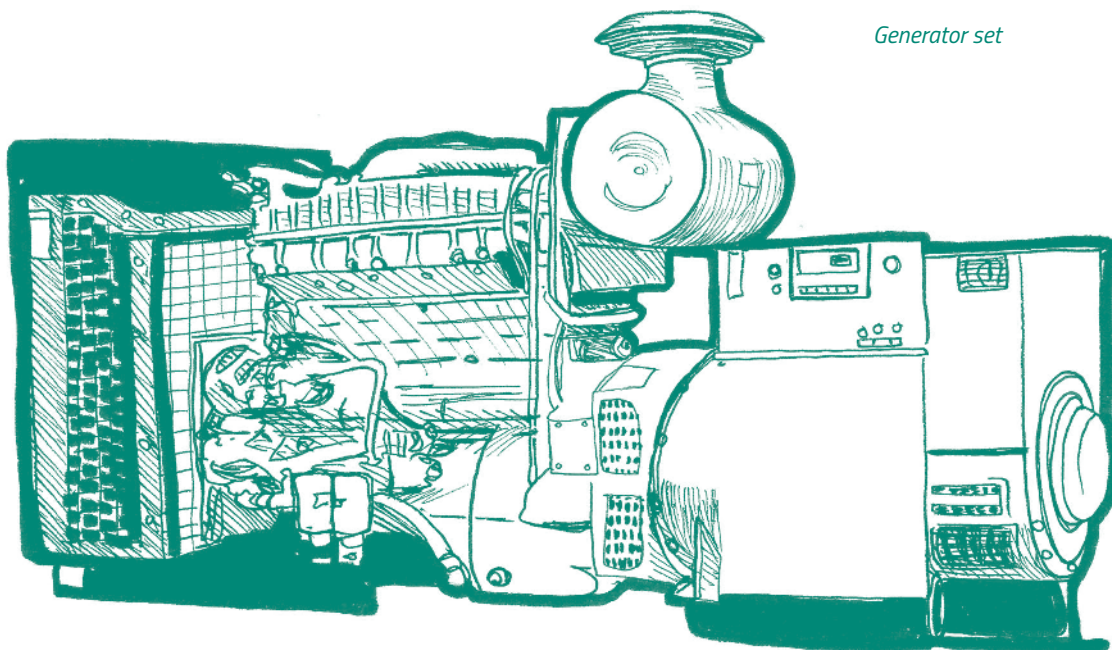

Generator set

notes

EXERCISES AND DISCUSSION POINTS

1. Provide examples of routine maintenance of a bucket elevator.
2. What is annual maintenance? What is the best time to carry out annual maintenance of a seed-cleaning plant?
3. What is "downtime" in the context of a seed-processing plant? Why is downtime undesirable? How can you avoid downtime or keep it to a minimum?
4. Explain whether you consider the following activities to be routine or corrective maintenance:
 - Greasing a bearing on the elevator boot
 - Removing sisal twine/thread from the intake hopper
 - Replacing a broken link belt in an air-screen cleaner
 - Changing the fuel and oil filter in a generator engine
 - Painting the building that houses the seed cleaner
 - Fixing a new nylon brush on a rotary screen air cleaner
 - Welding a duct on a seed cleaner
 - Replacing an electric cable running from the control panel to the cleaner
5. How can poor maintenance of a weighing scale affect your seed enterprise business?
6. As the operator responsible for a seed-processing plant, what would you do if the plant suddenly stalled and stopped while in operation?

7

Health and safety in the processing plant

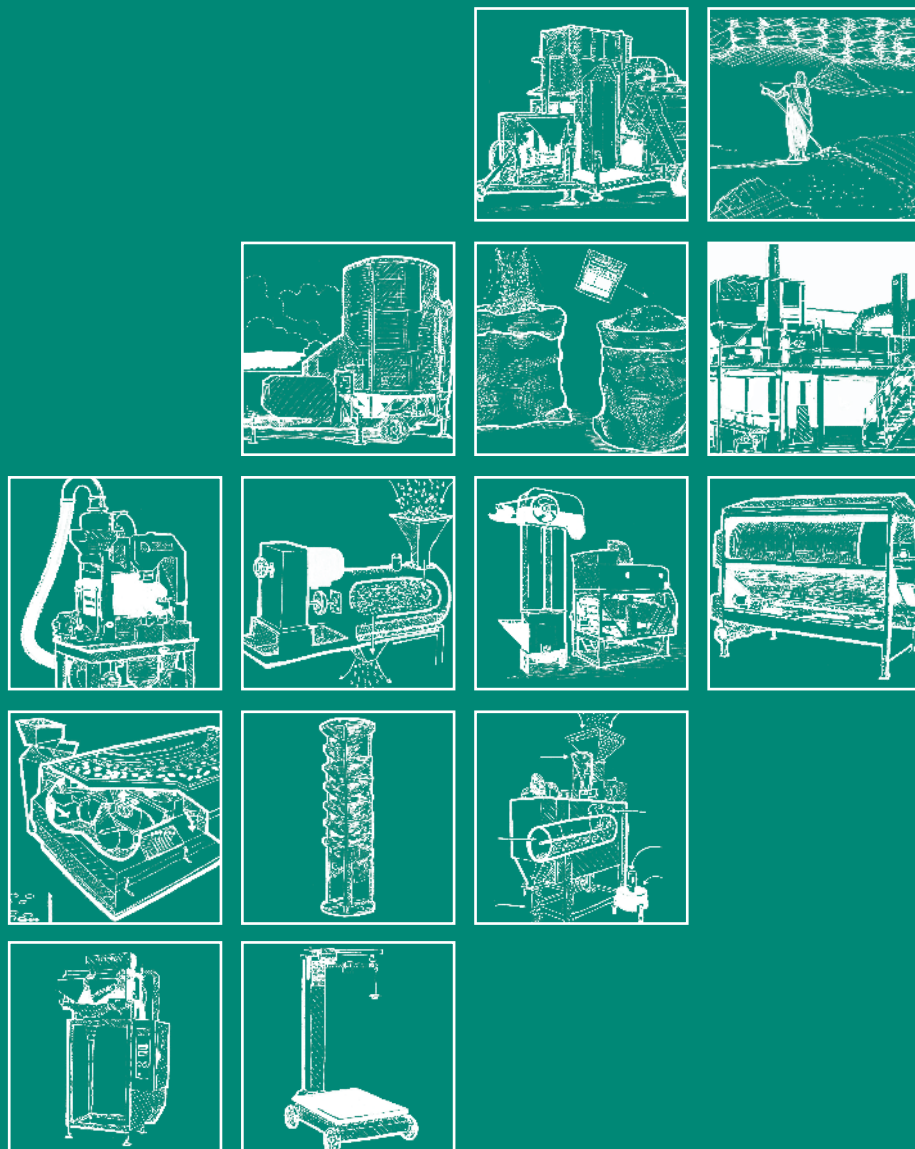

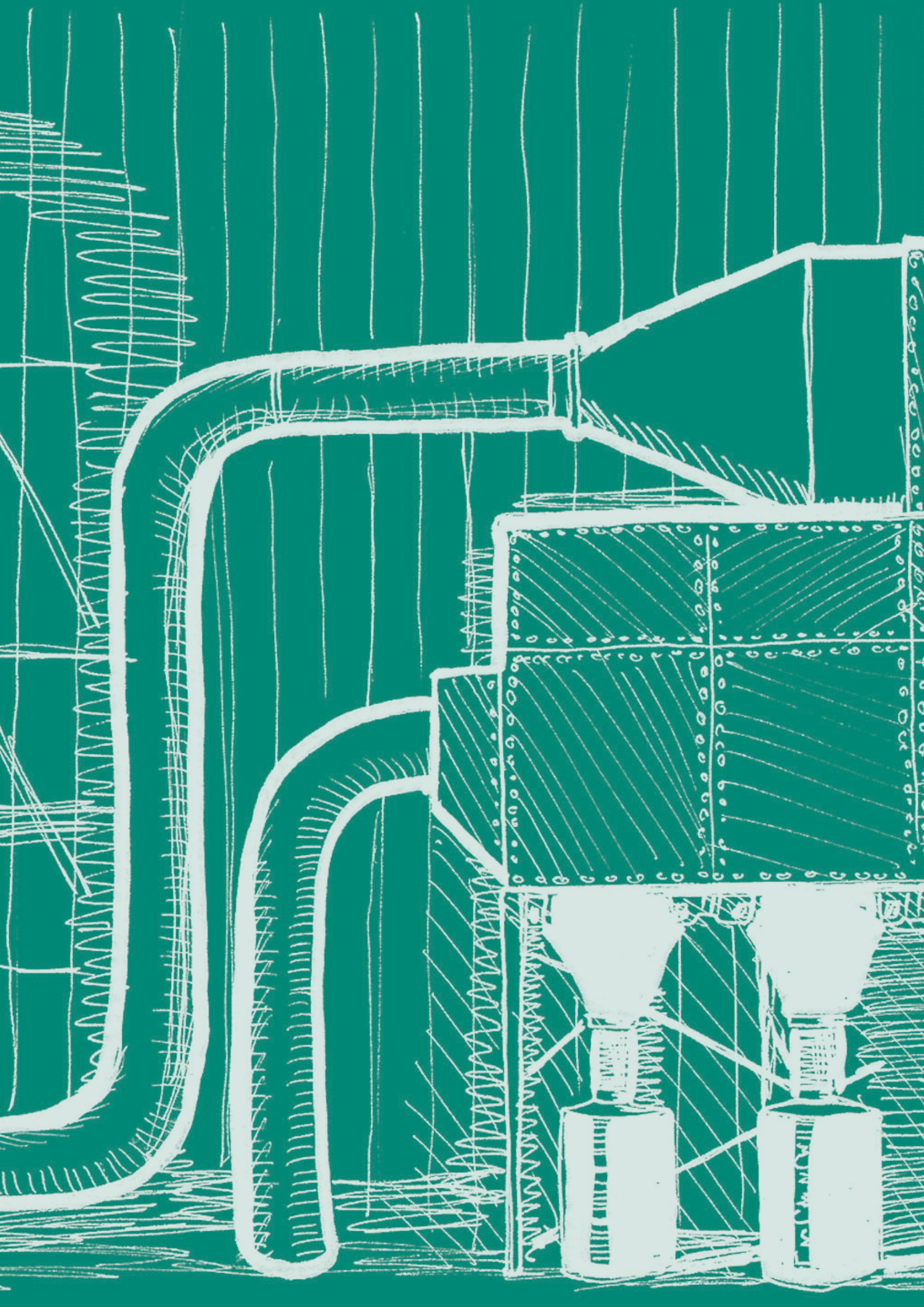

Health and safety in the processing plant



notes

Adherence to best practices and regulations on health and safety during seed processing is essential to ensure employee health, safety, comfort and performance, and to avoid negative impacts on the environment. Health and safety is relevant to **all aspects of seed processing**, including general housekeeping, dust control and seed treatment.

HOUSEKEEPING

The most important aspect of seed-processing maintenance is cleanliness. Cleaning must be a routine and continuous activity, carried out at least once a day. A **clean machine** is:

- safe;
- easy to inspect;
- easy to detect faults (e.g. leakages of lubricants, spillage of seed and dust);
- able to maximize product output; and
- efficient (e.g. air-cooled engines and radiators).

Keep all production machines clean and tidy. Practise good housekeeping, in season and off season.

Install machinery - or, if mobile, store machinery - in a properly roofed building for protection from adverse weather conditions. Inspect seed lots periodically and fumigate against storage pests when necessary (see Module 1 of the Toolkit). **Good housekeeping** is imperative at all times:

- Do not stack bags of seed on the machine deck, under the deck or on the processing floor.
- Remove loose items of wood, metal, tools, furniture etc. from the working area (they may cause accidents).
- Eliminate dust in the buildings and on machinery, with attention to ledges and other awkward places (dust reduces visibility and is a health hazard).
- Put back in place immediately any covers and guards on machines removed for inspection purposes.
- Comply with the rules and regulations of the local health act or factory act regarding cleanliness of the processing floor and environment.
- Wear proper protective clothing while on duty (machine operators and all attendants).
- Avoid loose hanging garments.

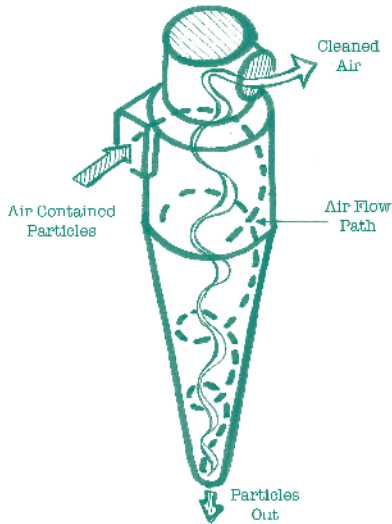

Parts of dust collection system

DUST COLLECTION AND CONTROL

Grain dust generated during seed processing can be a nuisance, a health risk and a safety hazard (particles charged with static electricity generated by friction of elevators and the cleaning process could lead to a chain reaction resulting in an explosion). For a safe and secure working environment, connect a **dust collection system** to areas or equipment where large quantities of dust are generated: intake pit, cleaner, bucket elevator and bagging points.

The dust collection system comprises a fan, separator and pipework. The separator consists of cyclones/filters or combination of the two. The system sucks the dust-laden air, separates the solid particles from the air and discharges the clean air into the atmosphere. The dust collection system must be in good working condition and properly functioning for the plant to process seed efficiently. Indeed, it is possible to **synchronize** the machinery in the processing line: if the dust collection system is not up and running, the other machines cannot operate.

Adjustment and maintenance of dust collection system

- Inspect the system during operation and remove and replace the collection bags below the cyclones regularly.
- Inspect regularly all air ducts. Check for blockages and leakages (especially at joints) and for wear (especially at bends). Adjust butterfly valves.
- Inspect periodically the fan motor. Check bearings, impeller and casing, couplings and transmission drives. Lubricate according to the manufacturer's recommendations.
- Inspect periodically cyclones and check for wear and tear. Clean or replace filters, and check pressure gauges (where applicable).
- Inspect periodically rotary valves (air lock valves) and check for wear of vanes, casing and bearings. Monitor lubricant levels of the drive mechanism and lubricate according to the manufacturer's recommendations.
- At the end of the season, thoroughly clean the system, inspect and check for worn or broken parts. Source the spare parts and replace where necessary. Repair and service the machine ready for the next season.

SEED TREATMENT

Seed treatment is potentially dangerous for people, animals and the environment. Specific training is necessary for operators handling seed treatment chemicals and treated seed. The risks include:

- Application of **incorrect dosage** of chemical. An inadequate dose is ineffective and useless, but an excessively high dose (especially in liquid or slurry) may harm the germinating seed.

7

- Accidental **exposure or poisoning** of operators involved in seed treatment operations. Handle seed treatment chemicals with care. Exposure occurs when the product is touched or when vapours are inhaled.
- Accidental **mixing of treated seed** with food or feed grain. Provide warning against the use of treated seed for human consumption or feeding animals. Ensure that the warning is clear (both words and symbols) and highly visible on the seed package.
- **Contamination of the environment.** Poor handling of treated seed or treatment chemicals may have a negative environmental impact.

notes

GENERAL SAFETY

Safety - being free from danger - is the **protection of persons and property** from all hazards related to machinery, processes, fire and acts of hostility. **Safe and healthy working conditions** are fundamental:

- Supply of appropriate personal protective equipment and clothing
- Adequate lighting and ventilation
- Properly guarded machinery
- Provision of adequate fire protection equipment
- Suitable washing and toilet facilities
- Working areas as free as possible from dust and noise
- Good housekeeping standards

Safety is an attitude: acquire it, cultivate, develop and practise it! Provide safety education and training so that personnel are aware of potential hazards and know how to avoid them. Staff need to know what to do when faced with a safety incident (e.g. intoxication, or an electrical, dust- or wood-related fire). **All accidents are avoidable!**

EXERCISES AND DISCUSSION POINTS

1. Why is it important, from a safety point of view, to keep the seed-processing environment and machines clean and tidy?
2. In which areas of a seed-processing plant is dust generated? Why must dust be controlled and collected?
3. What precautions would you take to minimize the harmful effects of seed treatment?

⑧ Selecting, owning and managing seed-processing machinery

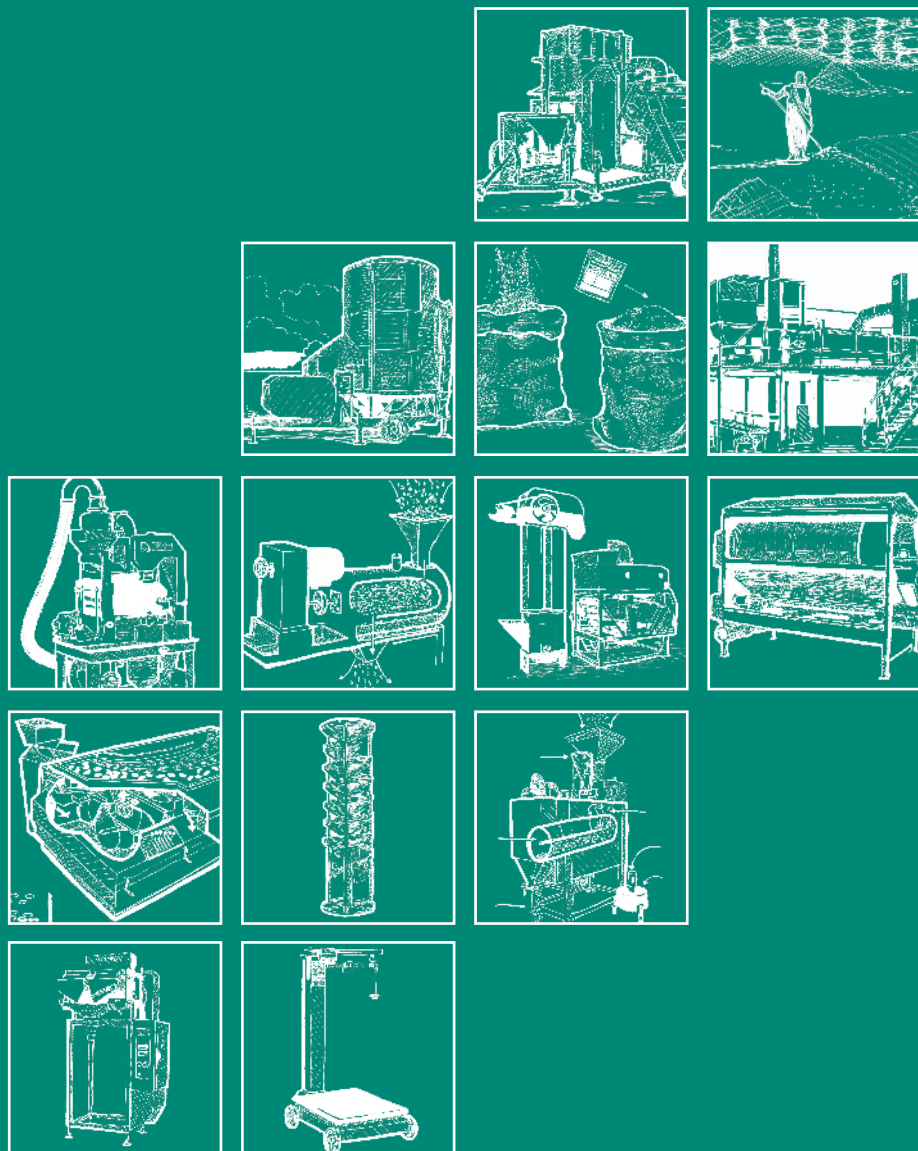



Selecting, owning and managing seed-processing machinery

A seed enterprise may choose to invest in processing equipment for a particular reason. However, the enterprise can then reap **multiple benefits** from the acquisition.

BENEFITS OF OWNING SEED MACHINERY

- Control of activities and capacity to carry them out in a timely manner
- High-quality performance
- Increased scale of operation
- Reduced labour costs
- Fewer labour-associated problems
- Extra income (using surplus capacity to do jobs for third parties)
- Potential savings (compared with hiring machines)

SELECTING AND OWNING THE RIGHT SEED-PROCESSING MACHINERY

Once the enterprise decides to invest in **machinery**, it is vital to seek **expert information and advice** in the following areas:

- Production flow processes.
- Species to be processed: quantity (tonnes/year/species) and timing (processing month[s] for each species).
- Working hours required, including stoppage times, and eventual need for shift work.
- Identification, specification and selection of machinery for optimal performance in terms of capacity, product quality, operational reliability, applicable technology and suitability.
- Projections for plant upgrade or expansion.
- Legal and regulatory provisions.

Establishment of a seed-processing plant requires careful consideration of:

- crops to be handled;
- undesirable crops and weeds contaminating seed lots;
- initial quality of seed lots;
- plant capacity at intake;
- delivery of raw seed; and
- power and labour - availability and source.

notes

To select the most appropriate processing machines, consider carefully your **desired objectives** in terms of:

- purity - depends on the pre-cleaning, fine cleaning and grading (by size, length, shape and specific weight) processes adopted;
- seed treatment - entails the choice between powder, slurry and liquid; and
- packaging - involves bagging, holding bins and suitable conveyors.

Once you define your objectives, you can select the equipment. Make provision for **flexibility**, allowing for bypasses and return chutes; reserve machine capacity for problem seed lots; future equipment upgrades; and plant expansion. Decide whether the plant is to be mobile or stationary. Install or store the equipment in a suitable building.

ORDERING AND BUYING SEED-PROCESSING MACHINERY

Invest in quality equipment with proven performance. Buy from manufacturers and dealers with a good reputation for after-sales service. Expert knowledge must be available to provide back-up service, repair and spare parts, because **maintenance is key**. A poorly maintained machine is expensive to operate and produces a poor quality finished product that cannot compete on the market. Keep a concise inventory of fast-moving parts and equip the maintenance team with the tools and equipment needed to carry out repairs.

On delivery, inspect machinery for damage, and ensure that it is properly installed, tested and commissioned. Provide training to operators on all aspects of operation, maintenance and safety. The enterprise must be fully aware of warranties and other contractual obligations in the supply contract. Verify that the correct user manuals are delivered with the machinery.

MANAGING SEED-PROCESSING MACHINERY

Once the machinery is purchased and installed, the enterprise must optimize its capital investment. Seed-processing machinery management aims to:

- enhance the reliability of the equipment; and
- lower the operational costs without compromising safety.

Spread fixed costs by keeping the plant busy throughout the year. Process seed of different crops (e.g. wheat, rice, barley, maize and vegetables), carrying out screen changes as appropriate. However, note that equipment normally used for cereals is seldom suitable for vegetables because of the difference in scale of operation.

Effective management of seed machinery depends on:

- operator training;

notes

Tools

Ensure that a range of proper tools (e.g. hand tools, power tools, greasing guns, air compressor, electrical meters and measuring devices) are always available for servicing and repairs.

Records

Maintain a record-keeping system for all management, production and maintenance activities carried out on the machinery. The system must be easy to understand and use, the information accurate and relevant. It must keep track of all expenses, including purchase, licenses, insurance, fuels, oils and greases, spare parts and labour. Each machine needs its own bin card, kept in a file or attached to the machine. Good records help appreciate the costs of owning and operating the machinery. There are different kinds of records:

Operation and maintenance tools

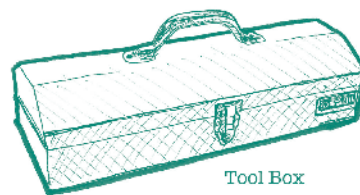

Tool Box



Hand Tools

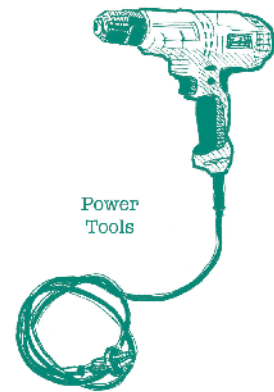

Power Tools



Gloves

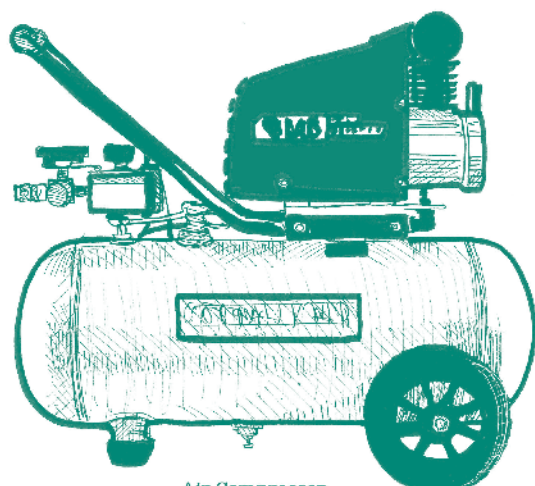

Air Compressor

8

- Machine history - detailing servicing and repairs, recorded on a card tagged onto the machine or kept in a file. It may include other information (e.g. cost of labour and spare parts fitted). This record helps to plan maintenance, anticipating orders for replacement parts, and is useful for evaluating performance.
- Plant operation log sheet - indicating fuel consumption and running hours. Power accounts for a substantial proportion of the total operating costs of seed production. It is important to monitor energy consumption – whether mains electricity or generator fuel.
- Stock control - discussed in Module 1 of the Toolkit.

notes

Housekeeping

For good management of the seed-processing machinery, health and safety are fundamental. For a safe working environment, cleanliness and good housekeeping are essential.

EXERCISES AND DISCUSSION POINTS

1. Discuss two main reasons why your enterprise has invested or would be interested in investing in seed-processing machinery.
2. Does your seed enterprise keep any records of machinery operation and maintenance? Explain why/why not.
3. A newly established seed enterprise plans to purchase new machinery for processing seed. What advice should they seek before buying the machinery?
4. Why are owner manuals an important element in the seed-processing plant?
5. Why is it vital for the owner to keep detailed records of seed-processing machinery?

The Seeds Toolkit

Seeds are the vehicle for delivering the improvements in a crop to the farmer's field. They are therefore a critical input in agricultural production. Seeds are unique in that they must remain alive and healthy when they are used and they are also the input that farmers can produce by themselves.

These factors were borne in mind in preparing the Seed Toolkit that comprises the following six interrelated modules:

1. **Development of Small-Scale Seed Enterprises.** This provides a stepwise guide for the establishment of commercially viable seed enterprises in farmers' communities. It covers the critical steps from the business plan to the production of seeds for sale.
2. **Seed Processing.** This presents the underlying principles of seed processing, the equipment used and the overall best practices from reception through conditioning to final delivery to customers. This module focuses on the use of affordable small-scale equipment for seed processing and sowing that may also be fabricated locally.
3. **Seed Quality Control.** This assists seed practitioners and other stakeholders in meeting the set quality standards for seeds and in implementing procedures for certification. The topics covered include field inspections and seed conditioning, packaging and tagging, storage, sampling/testing, and distribution.
4. **Seed Sector Regulatory Framework.** This provides information on the elements of the regulations that govern the seed value chain – from variety registration through quality seed production to distribution and marketing. The materials covered include information about national seed policy, seed law and regulations, their definitions, purpose and interactions.
5. **Seed Marketing.** This presents the underlying principles for valuing and exchanging seeds. This module describes all the activities that are undertaken in getting seeds from the producers to the end-users or farmers. The reader is provided with guidance on how to conduct relevant research of the market for seeds, develop effective marketing strategies, articulate a marketing plan and manage the associated risks.
6. **Seed Storage.** It is estimated that 25–33 percent of the world grain crop, including seeds, is lost each year during storage. To avert this obvious drawback to food security and nutrition, this module provides the underlying principles for effective seed storage and the associated practices. The module provides guidance on the preservation of seeds under controlled environmental conditions to maximize seed viability for the long periods that may be required from harvesting through processing to planting.

This module presents the underlying principles of seed processing, the equipment used and the overall best practices from reception through conditioning to final delivery to customers. This module focuses on the use of affordable small-scale equipment for seed processing and sowing that may also be fabricated locally.



ISBN 978-92-5-130950-6



9 789251 309506

CA1491EN/1/09.18